

Digital Envelope Detection: The Good, the Bad, and the Ugly

By Richard Lyons

Recently I've been thinking about the process of envelope detection. Tutorial information on this topic is readily available but that information is spread out over a number of DSP textbooks and *many* Internet web sites. The purpose of this blog is to summarize various digital envelope detection methods in one place.

Here I focus of envelope detection as it is applied to an amplitude-fluctuating sinusoidal signal where the positive-amplitude fluctuations (the sinusoid's *envelope*) contain some sort of information. Let's begin by looking at the simplest envelope detection method.

Asynchronous Half-Wave Envelope Detection

Figure 1 is a digital version of a popular envelope detector used in the analog world for amplitude modulation (AM) demodulation in analog AM receivers. The job of this envelope detector is to extract (*detect*) the low frequency amplitude envelope signal (the dashed curve) from the incoming RF signal.

Note: Although the signal waveforms in Figure 1 appear to be continuous, keep in mind that they are indeed discrete-time numerical sequences (digital signals).

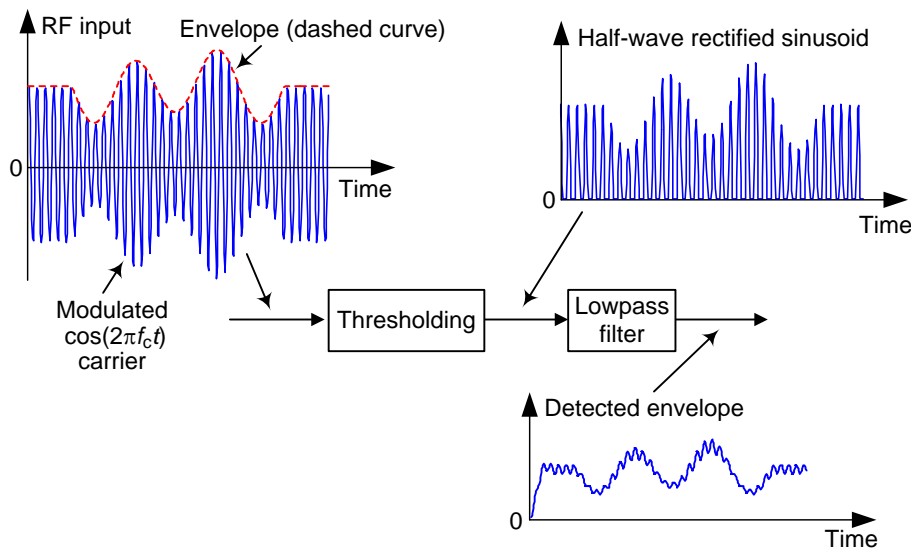

Figure 1: Asynchronous half-wave envelope detector.

Due to the harmonics (multiples of the incoming f_c carrier frequency) generated by half-wave rectification in Figure 1 and possible spectral aliasing depending on the system's f_s sample rate, careful spectrum analysis of the half-wave rectified sinusoid is necessary to help you determine the appropriate cutoff frequency of the digital lowpass filter. Here I used a simple third-order IIR lowpass filter to generate *all* of the output envelope waveforms presented in this blog.

This simple detector is called "asynchronous" because it need not generate a constant amplitude copy of the incoming RF sinusoid, as do some of the other detectors we'll be discussing.

Asynchronous Full-Wave Envelope Detection

We can reduce the high-frequency noise riding on the Figure 1 detector output by performing full-wave rectification as shown in Figure 2 [1].

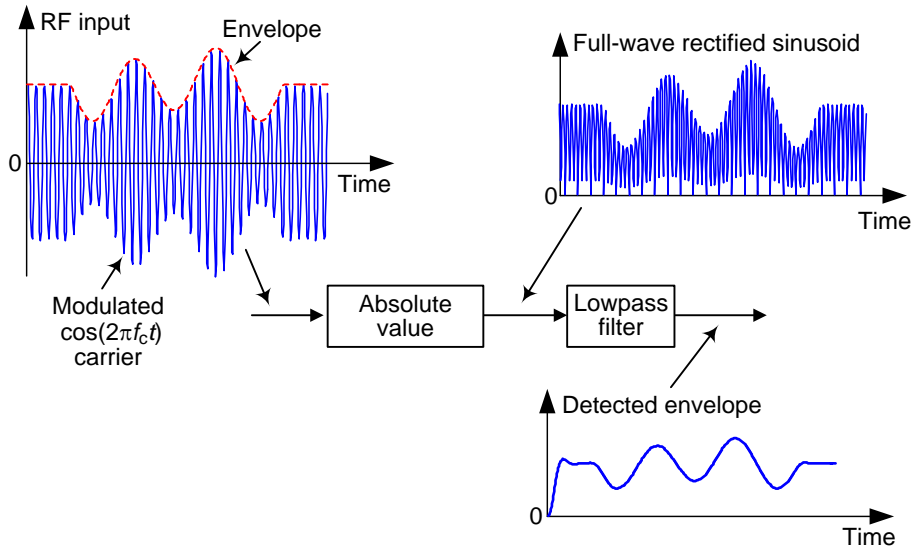

Figure 2: Asynchronous full-wave envelope detector.

Here the lowest-frequency spectral harmonic at the filter's input is $2f_c$ Hz. So that harmonic is more thoroughly attenuated at the Figure 2 lowpass filter output compared to the first f_c Hz harmonic at the Figure 1 filter output.

Asynchronous Real Square-Law Envelope Detection

Figure 3 is a digital version of a popular *square-law* analog envelope detector (sometimes called a "product detector").

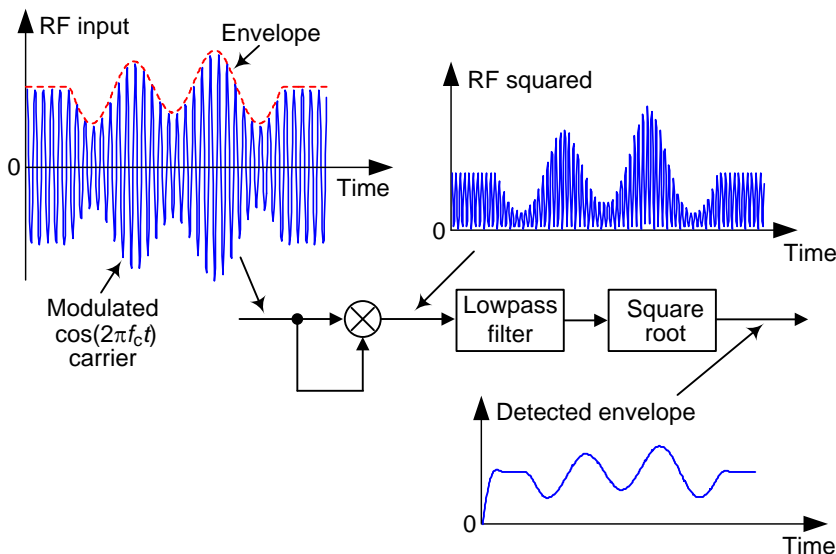

Figure 3: Asynchronous real square-law envelope detector.

Here the spectral harmonics at the filter's input are the same as those in Figure 2. References [2,3] give a mathematical description of the Figure 3 envelope detector.

Asynchronous Complex Envelope Detection

Figure 4 shows a popular digital envelope detector that uses a Hilbert transformer to compute a complex-valued version of the incoming signal. (This detector is described in more detail in Reference [4].)

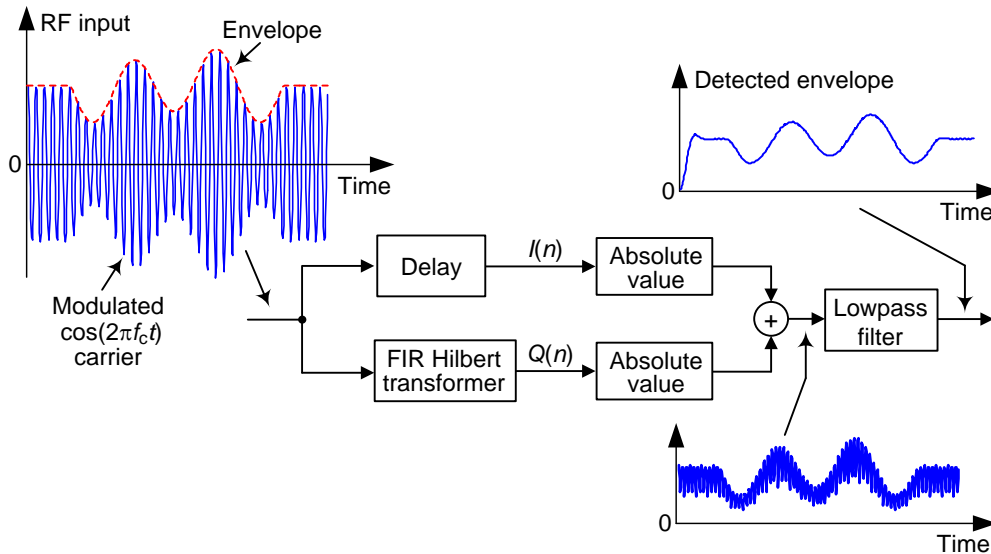

Figure 4: Asynchronous complex envelope detector.

The above Hilbert transformer need not be super high-performance, such as a wideband one whose passband extends from nearly zero Hz to nearly half the sample rate ($f_s/2$ Hz). The transformer's passband need only be wide enough to include the spectral energy of the incoming RF signal.

Asynchronous Complex Square-Law Envelope Detection

Another digital envelope detector that uses a Hilbert transformer is shown in Figure 5. (This detector is described in more detail in References [2,3].)

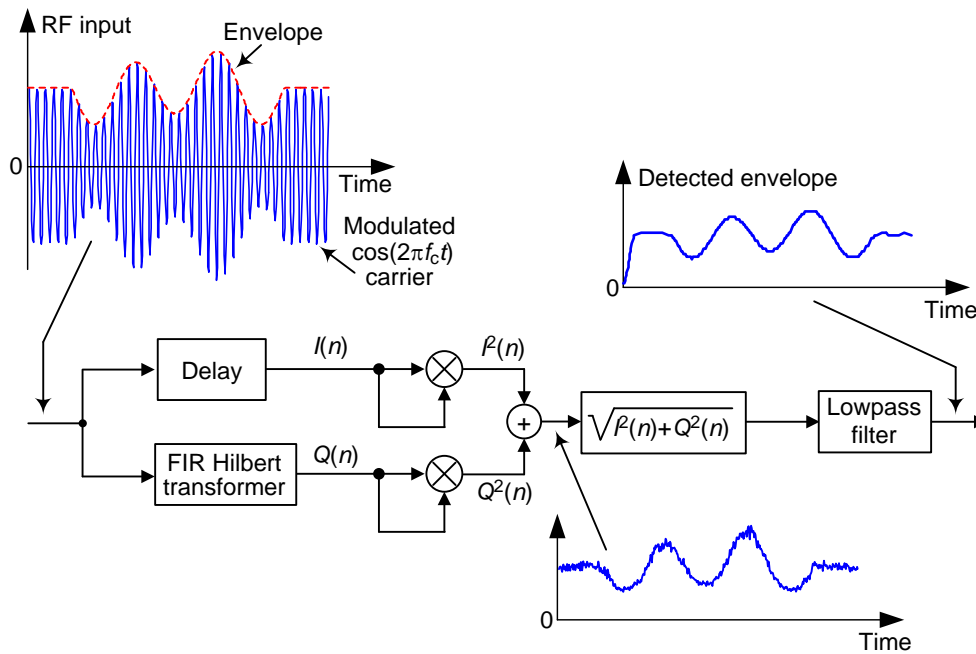

Figure 5: Asynchronous complex square-law envelope detector.

This is a most interesting envelope detector. Reference [5] touts this detector's advantage that no lowpass filtering is needed at the output of the square root operation. However, I have learned this only to be true for noise-free signals! In practical real-world applications the lowpass filter I've included in Figure 5 is necessary.

Synchronous Real Envelope Detection

Figure 6 shows an envelope detector that's called "synchronous" because the RF input signal is multiplied by a local oscillator signal whose frequency is f_c Hz. (This detector is sometimes called a "coherent envelope detector.")

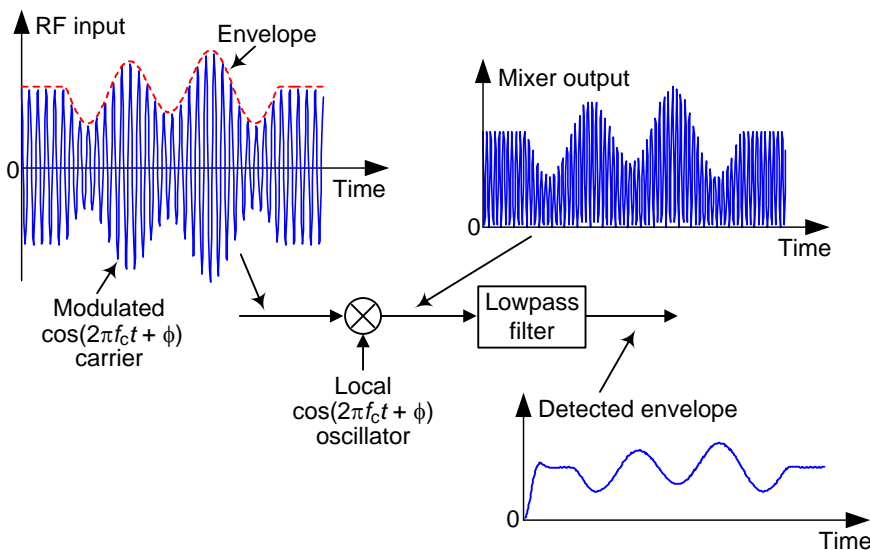

Figure 6: Synchronous Real Envelope Detector.

The complicated part of this detector is that the f_c Hz carrier frequency of the received RF input signal must be regenerated (a process called "carrier recovery") within the envelope detector to provide the local oscillator's $\cos(2\pi f_c t + \phi)$ signal. Another complication is that the local oscillator output must be in-phase with the input RF signal's sinusoid.

Reference [6] gives a detailed mathematical description of this synchronous envelope detector.

Asynchronous Complex Envelope Detection

Reference [7] proposes the Figure 7 envelope detector that compute a complex-valued version of the incoming signal.

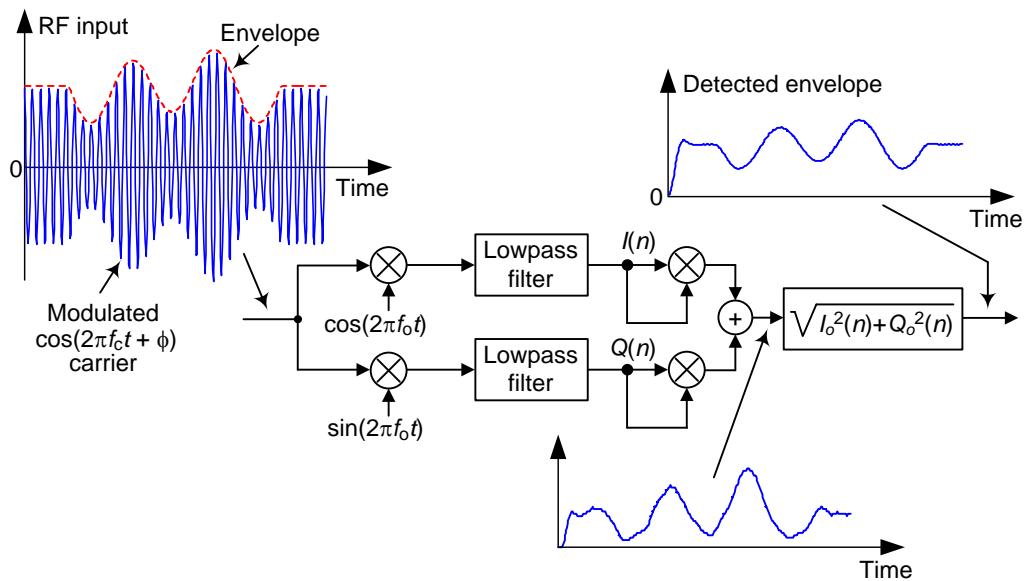

Figure 7: Asynchronous complex envelope detector.

This detector is asynchronous in operation because the local oscillators' f_0 frequency need not be equal to the f_c frequency of the incoming modulated RF signal. An f_0 within 25% of f_c is acceptable so long as the lowpass filters sufficiently attenuate spectral energy near $|f_c + f_0|$ Hz.

Because the $I(n)$ and $Q(n)$ sequences are in quadrature, phase cancellation occurs in the adder such that only spectral energy in the vicinity of zero Hz appears at the adder's output. As such, this detector is very tolerant of local oscillator frequency/phase drift just so long as the local cosine/sine oscillators remain in quadrature.

Although I haven't seen it in the literature it seemed to me that we can eliminate one of the filters in Figure 7 and implement that envelope detector as shown in Figure 8.

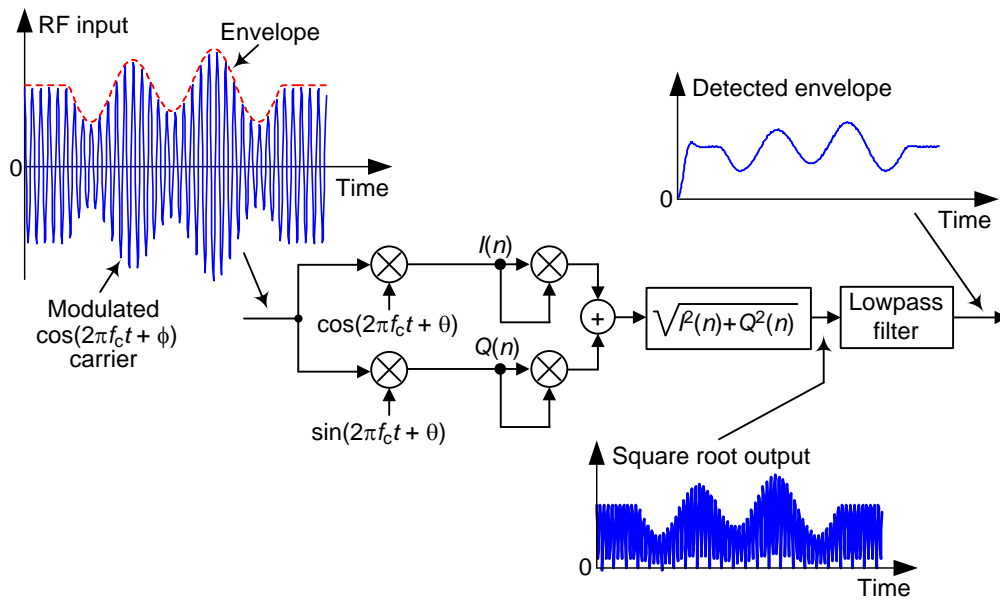

Figure 8: An alternate synchronous complex envelope detector.

Upon analysis of this Figure 8 detector I was surprised to determine that it's *exactly* equivalent to the Figure 2 asynchronous full-wave envelope detector! The reader can verify this by solving the following homework problem:

HOMEWORK PROBLEM FOR THE READER:

Assume an input sample to the Figure 8 detector has a value of A and the cosine oscillator's sample is $\cos(\alpha)$. What is the value of the output sample of the square root operation? Assuming the next input sample to detector has a value of $-A$ and the cosine oscillator's next sample is $\cos(\beta)$, what is the value of the next output sample of the square root operation?

There's no reason to discuss the Figure 8 detector any further.

Detector Performance: The Good, the Bad, and the Ugly



If you'll accept the definition of "performance" to indicate a detector's output signal-to-noise ratio (SNR) for a given noisy RF input signal, you'll notice that I've presented no statistical information on the performance of the various envelope detectors here. (That was not my goal.) However, I do have a few comments regarding performance.

For applications where high accuracy is not needed, such as automatic gain control (AGC) or amplitude-shift keying (ASK) demodulation, the Figure 1 detector is attractive because it's so easy to implement. Equally easy to implement, the Figure 2 detector has been used to process medical electromyogram (EMG) signals [8].

References [9,10] show the superiority of the Figure 4 envelope detector over the Figure 2 detector in a medical ultrasound signal analysis application.

Based on my very limited modeling of the various envelope detectors, with:

- Sample rate: $f_s = 8000$ Hz
- RF carrier frequency: 600 Hz
- Modulation: 60 Hz sine plus 30 Hz cosine wave
- Modulated RF signal SNR: +20 dB
- Lowpass filter: 3rd-order Butterworth IIR (≈ 240 Hz cutoff frequency)

I rank the detectors' performances (from best to worst) as follows:

Highest output SNR: Asynch Complex (Figure 4)
↓ Asynch Complex Square-Law (Figure 5)
↓ Asynch Full-Wave (Figure 2)
↓ Asynch Complex (Figure 7)
↓ Synch Real (Figure 6)
↓ Asynch Real Square-Law (Figure 3)
Lowest output SNR: Asynch Half-Wave (Figure 1)

If you need an envelope detector in some real world application, I suggest you implement several of the above detectors to see which one is optimum for your signals and your f_s data sample rate. To quote Forrest Gump, "And that's all I have to say about that."



References

- [1] C. R. Johnson Jr., W. A. Sethares, and A. G. Klein, *Software Receiver Design*, Cambridge University Press, 2011, pp. 82-84.
- [2] Tretter, S. A.,
<http://www.ece.umd.edu/~tretter/commlab/c6713slides/ch5.pdf>
- [3] Tretter, S. A., *Communication System Design Using DSP Algorithms*, Springer, 2008, pp. 123-127.
- [4] Lyons, R., *Understanding Digital Signal Processing*, 3rd Ed., Prentice Hall Publishing, 2011, pp. 786-784.
- [5] Ciardullo, D., Fast Envelope Detector, *Brookhaven Nat. Lab., AGS/AD/Tech. Note No. 386*,
<http://www.agsrhichome.bnl.gov/AGS/Accel/Reports/Tech%20Notes/TN386.pdf>

- [6] Abdel-Aleem, M.,
http://www.fcet.staffs.ac.uk/alg1/2004_5/Semester_1/Communications,%20COMMS%20%28CE00038-2%29/W5_AM_Demodulation&FM.pdf
- [7] Proakis, R. M., *Digital Signal Processing in Communications Systems*, Chapman & Hall, 1994, pp. 235-238.
- [8] Rose, W.,
<https://www.udel.edu/biology/rosewc/kaap686/notes/EMG%20analysis.pdf>
- [9] Jan, J.,
https://books.google.com/books?id=2xrNBQAAQBAJ&pg=PA299&lpg=PA299&dq=%2B%22envelope+detection%22+%2B%22absolute+value%22&source=bl&ots=rSo4mj6vH&sig=RYGS_mcoNBt56k7ZI7IjIARgynxk&hl=en&sa=X&ved=0ahUKEwjt-PertM_LAhUGKWMKHxpuB1Y4ChDoAQg7MAY#v=onepage&q=%2B%22envelope%20detection%22%20%2B%22absolute%20value%22&f=false
- [10] Jan, J, *Medical Image Processing, Reconstruction and Restoration: Concepts and Methods*, CRC Press, 2005, pp. 299-300.