

H-BRIDGE

PHASE U

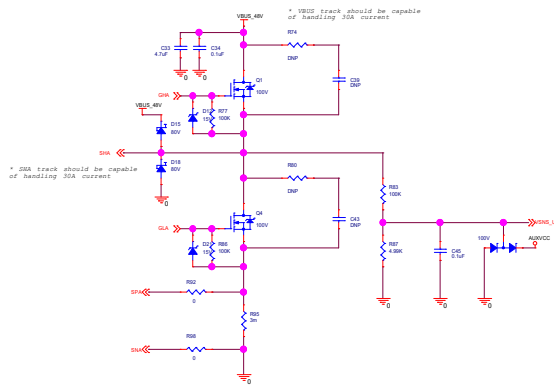

PHASE V

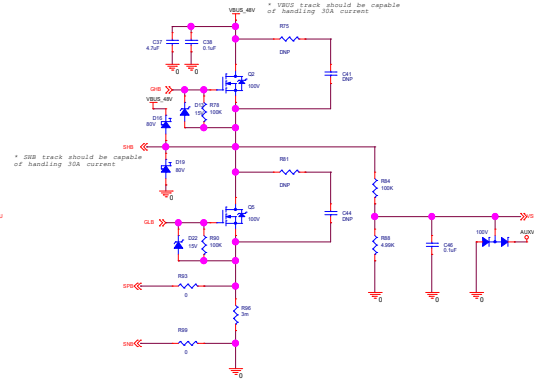

PHASE W

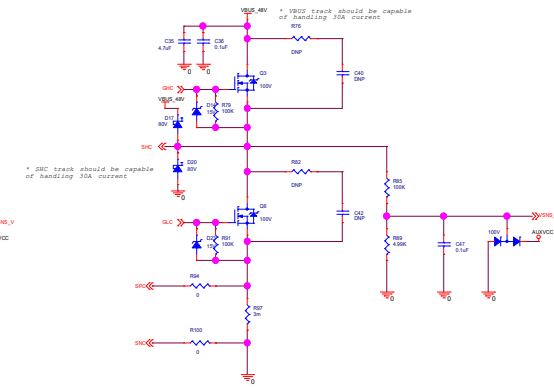

NOTE: PLACE HEAT SINKS FOR MOSFETS

POWER INPUT

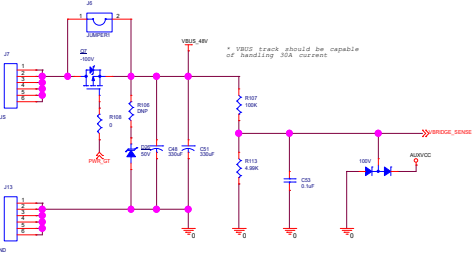

MOTOR CONNECTORS

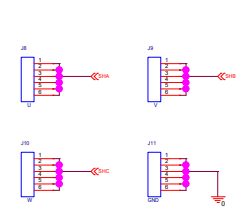

HALL EFFECT CONNECTIONS

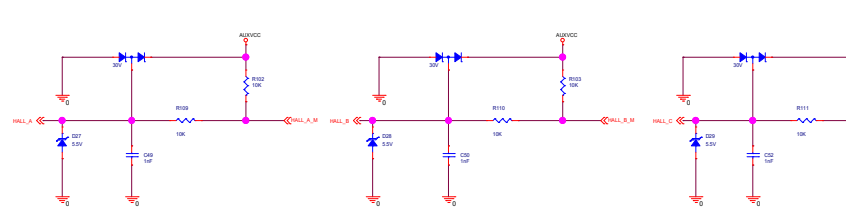

ENCODER INPUT

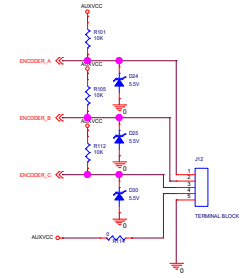

HALL INPUT

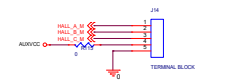

NOTE: PLACE HEAT SINK FOR MOSFET

DECELERATION

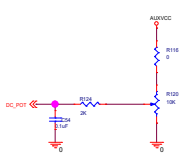

ACCELERATION

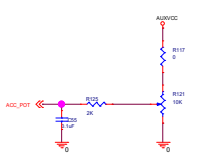

SPEED

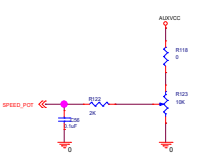

FORWARD / REVERSE

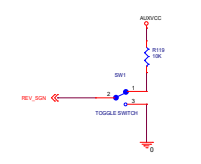

DECELERATION ALTERNATIVE

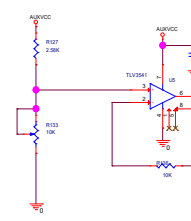

ACCELERATION ALTERNATIVE

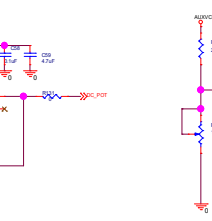

SPEED ALTERNATIVE

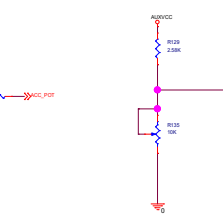

DYNAMIC BRAKING

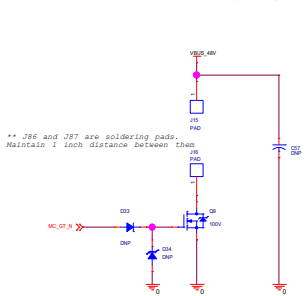

P MOSFET GATE DRIVE

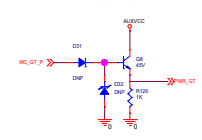

| | | |
|-----|--------------------|-----|
| REV | BLOCK/ACTOR DRIVER | REV |
| REV | ISSUE/REV | REV |
| REV | DATE | REV |