

Manual

Abt. / Name
FREIGABE
31. Jan. 2013

Abt. / Name
FREIGABE
31. Jan. 2013

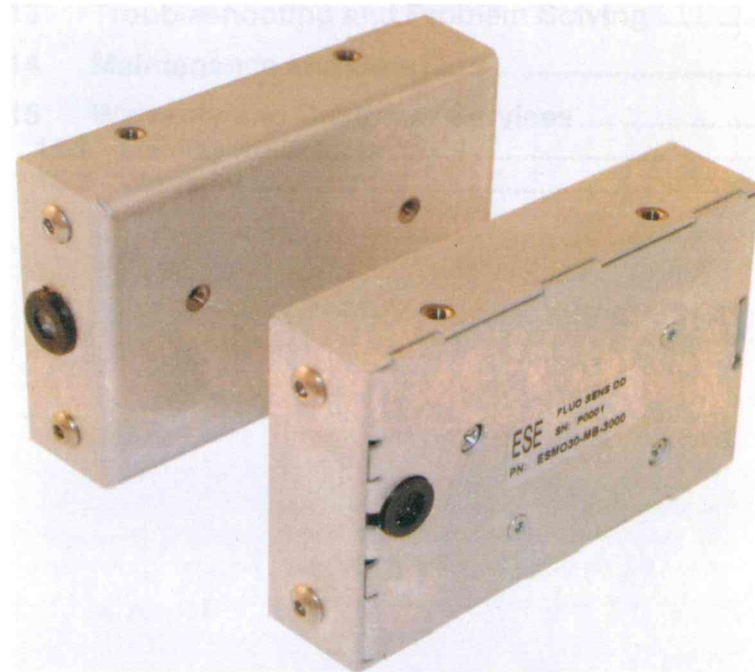

Manual

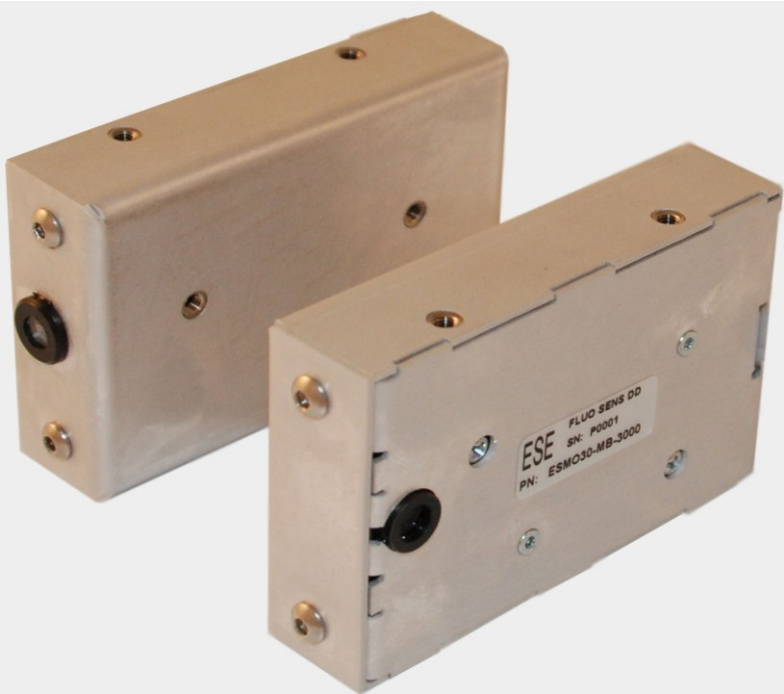

Notice

All rights reserved.

The information contained in this document is subject to change without notice.

Reproduction or republication of this document in any form or format is prohibited without the written consent of QIAGEN Lake Constance GmbH.

Trademarks

Trademarks and labels used are the property of their respective owners.

Copyright Information

User Manual for FLUO SENS integrated

Document Number ESMO30-DH-1001

Document Revision 05 / January 2013

© Copyright 2009/2012 by QIAGEN Lake Constance GmbH

Printed in Germany

QIAGEN Lake Constance GmbH

Jacques-Schiesser-Strasse 3

D-78333 Stockach

Germany

Tel: +49 (0) 7771-9166-0

Fax: +49 (0) 7771-9166-218

Email: info@qiagen.com

Website: www.qiagen.com

QIAGEN Lake Constance GmbH is certified according to ISO 9001 and EN 13485.

Table of Contents

1	General Product Description	4	10.7	Examples	19
2	Technical Specifications	5	10.8	Reading “Version”	19
3	Connections	6	10.9	Reading “Temperature”	19
4	Physical Dimensions	7	10.10	Reading “Method Type”	19
4.1	ESMO40-MB-xxxx Detector	7	10.11	Reading measurement value “On Value 1”	19
4.2	ESMO30-MB-xxxx Detector	7	10.12	Setting “Start Method Command”	19
5	Operating Conditions	8	10.13	“Start Method Command” and Reading Data	19
5.1	Environment	8	11	Controlling via Hyper Terminal	20
5.2	Safety Instructions	9	12	The FL Digital Program	20
6	Contents of the FLUO SENS integrated Package	10	13	Troubleshooting and Problem Solving	21
6.1	Start up	10	14	Maintenance and Care	22
6.2	Mounting	10	15	Warranty and Customer Services	22
7	Establishing Connection with a Computer	11	15.1	Liability for Defects	23
7.1	Connecting a Single Detector	11	15.2	Warranty	23
7.2	Connecting Multiple Detectors	11			
8	Instructions for Usage in Compliance with EMC-Directive 89/338 EWG	12			
8.1	EMC-Safety Precautions	12			
8.2	Switching on the Device	12			
8.3	Switching off the Device	12			
9	Operation	13			
9.1	MODBUS-ASCII	13			
10	Configuring a MODBUS-Protocol	14			
10.1	Longitudinal Redundancy Check (LRC)	14			
10.2	MODBUS Function Codes	14			
10.3	Function-Code 03: Reading up to 16 16bit-Registers	15			
10.4	Function-Code 06: Writing of 16 16bit-Registers	15			
10.5	Register Assignment	16			
10.5.1	Definitions	16			
10.6	FLUO SENS integrated Memory Allocation	17			

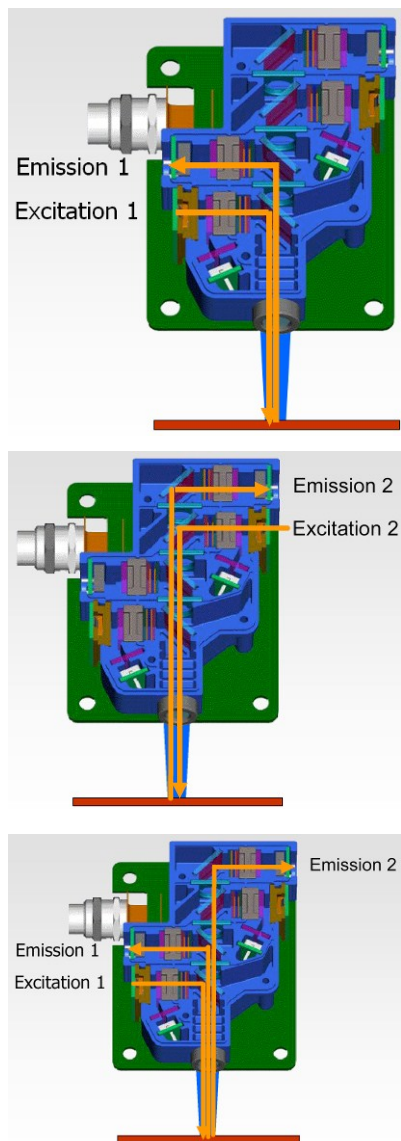

1 General Product Description

Confocal fluorescence detector for the simultaneous measurement of two separate fluorescent dyes.

- Ultra-compact fluorescence detector
- High sensitivity (e.g. Fluorescein down to 10^{-12} mol/l)
- Confocal optics
- Contact-free measurements on surfaces and in fluids
- 1 or 2 intensity controlled excitation light sources
- 1 or 2 highly sensitive, low-noise, long-term stable photodiodes
- Broad spectrum of filters and excitation light sources for a range of fluorescent dyes
- Robust metal housing
- Digital command interface

The unique fluorescence detector is the perfect solution for implementation in compact and mobile fluorescence detectors or for online measurements in automated processes.

The confocal optics allows contact-free measurements on surfaces and in liquids in the presence of ambient light.

The highly sensitive detector measures fluorescent samples down to very low concentrations and is easy to integrate as a component into your instrument.

The compact and robust module contains a complete fluorescence measurement device: precise micro-optics, powerful excitation light sources, highly sensitive sensors and microprocessor controlled electronics.

Calibration data and correction factors can be stored in the detector and applied directly to the raw data.

Consequently the detector module provides direct results, not just raw data. Measurement results can be accessed via a simple serial interface. External devices such as PCs, embedded controllers or PLCs can readily access measurement results via the integrated serial interface.

2 Technical Specifications

Performance	
Absolute Detection Limit	e.g. $<10^{-12}$ mol/l Fluorescein-Sodium in 0.1N sodium hydroxide
Linearity	4 Decades
Noise level	<1 mV @ max. range
Short term stability	$\leq 3\%$ / h, for 1 second measurement interval
Excitation	High performance-LED
Detection	Low-noise, precision Si-Photodiode
Reference signal measurement	Feedback loop with direct measurement of excitation intensity
Measurement intervals	0.1 seconds to hours
Measurement range	2 mm ² focused and 25 mm ² unfocused
Distance (Detector/Object)	2 mm focused to 25 mm unfocused
Available excitation wavelengths	265nm .. 980nm
Available detection wavelengths	365nm .. 980nm

Specifications given in the list above are for reference only. Exact specifications for the individual detectors are given in the corresponding data sheets.

Environmental Conditions	
Temperature Range	+10°C to +40°C
Air humidity	20% - 70% rel. humidity, without condensation
Air Pressure	300 - 1060hPa

Mechanics	
Housing	Aluminum, anodized
Dimensions (without adapter)	64x47x17.8mm ³
Weight	90g
Protection Class	IP20

Electronics	
Power Supply	+5VDC $\pm 5\%$, ripple ≤ 20 mV for electronics +5VDC ripple ≤ 20 mV for LED
Power Input	Detector: 30mA LED: ≤ 150 mA (depending on LED)
Interface	Serial, 57600 baud, 1 start byte, 8 data bytes, no parity, 1 stop byte
Interface models	TTL- / RS485-level (0 / 3.3V) RS232-level ± 6 V
Connectors	10 way flex cable MOLEX 98267-0257 mating receptable MOLEX 52610-1071

3 Connections

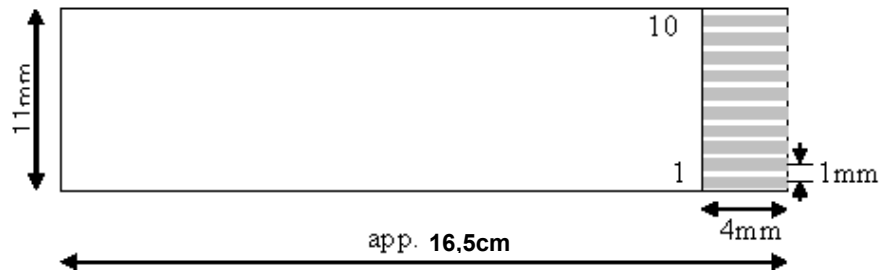

The FLUO SENS integrated features a 10way flex cable in the rear part of the housing (see 4.1 and 4.2). This flex cable is used for communication and power supply. Dimensions are shown left.

Flex cable type: MOLEX 98267-0257

Matching connector (SMD) MOLEX 52610-1071 (not included)

Pin assignment of the flex cable is shown in the table left. Note the following:

*) : These inputs do not provide internal pull up resistors. In normal operation they should be tied to +5V/+3.3V.

**) : The levels of the serial interface are with respect to the detector type either $\pm 6V$ (RS232), 0/+3.3V (TTL).

In the TTL-version the TxD-signal (pin 3) is disconnected when not used for data transmission. So, multiple devices can be connected in parallel. All devices will receive data simultaneously, activate the TxD pin and respond only if the modbus address matches.

All ground return pins should be connected to achieve optimal quality measurement results.

Pinout of the connection cable		
Pin No.	Name	Description
1	Ground	Ground return for supply an communication signals
2	Ground	Ground return for supply an communication signals
3 ^{**)}	TxD	Output of the serial interface
4 ^{*)}	#Trigger	Low active input to trigger a measurement by hardware
5 ^{**)}	RxD	Input of the serial interface
6	Ground	Ground return for supply an communication signals
7 ^{*)}	#RESET	Low active input to reset the detector
8	+5V	Detector supply voltage +5VDC, $\pm 5\%$, acceptable ripple < 20mV power consumption $\leq 40\text{mA}$
9	Ground	Ground return for supply an communication signals
10	VLED	LED supply voltage +5VDC, acceptable ripple < 20mV power consumption (depending on LED type) $\leq 150\text{mA}$

4 Physical Dimensions

4.1 ESMO40-MB-xxxx Detector

The ESMO40-MB-xxxx has its detection axis parallel to the top plate. Physical dimensions are shown below.

The housing of the detector is connected to ground return.

To achieve precise alignment between the detector and the sample, the front lens is designed with a $\text{Ø}8\text{f}8$ fit (shown bottom left).

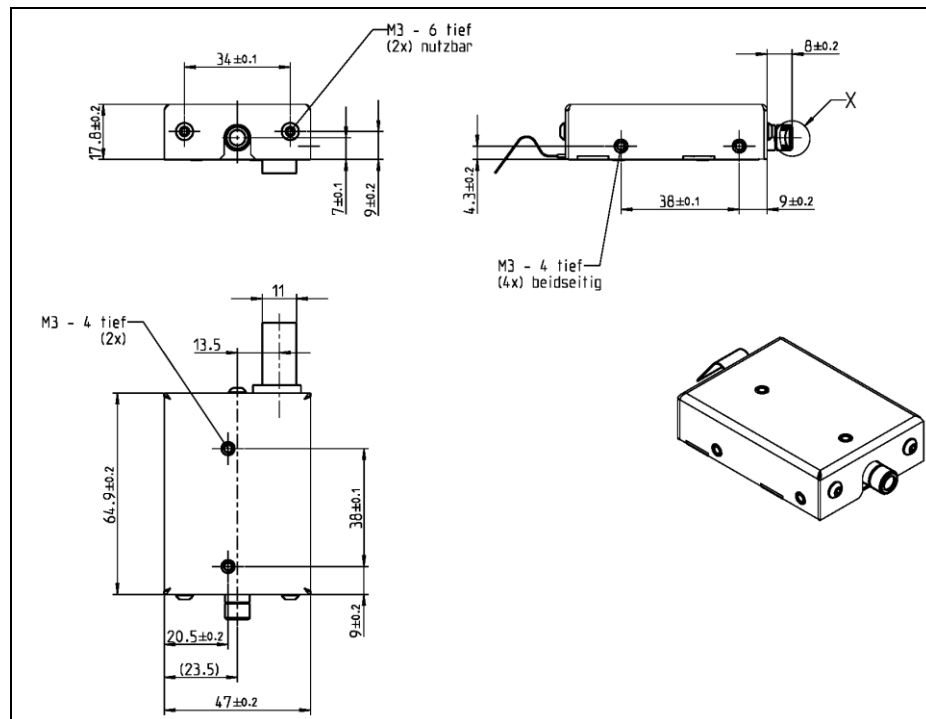

ESMO40-MB-xxxx Detector Dimensions.

4.2 ESMO30-MB-xxxx Detector

The ESMO30-MB-xxxx has its detection axis perpendicular to the top plate. Physical dimensions are shown below.

The housing of the detector is connected to ground return.

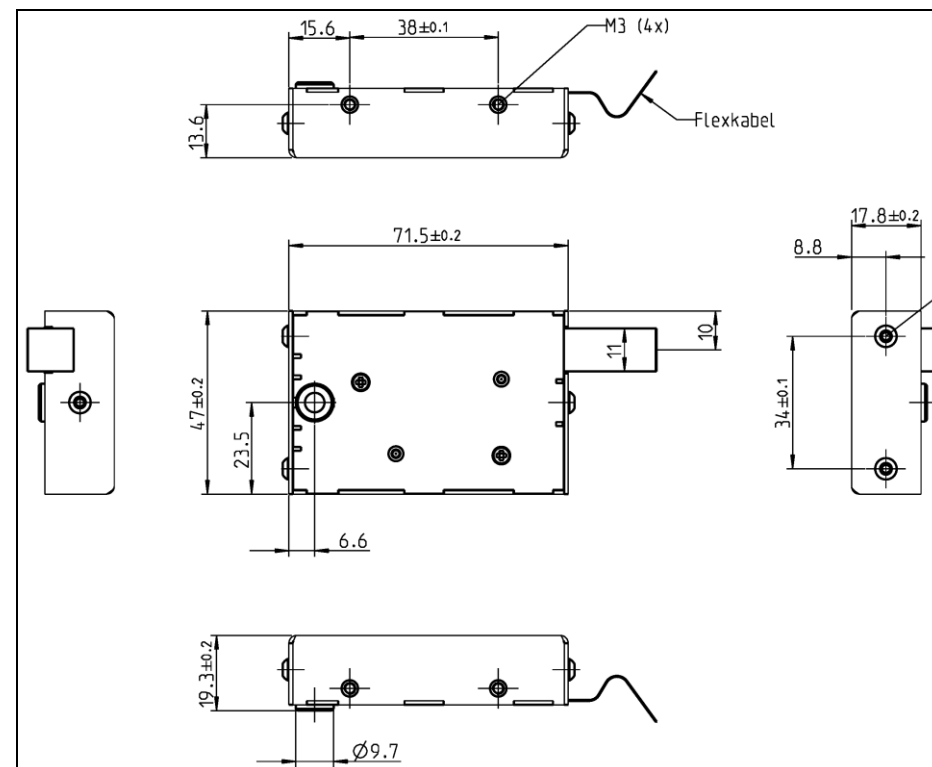

ESMO30-MB-xxxx Detector Dimensions.

4.3 ESMO35-MB-xxxx Detector

The ESMO35-MB-xxxx has its detection axis in 70° to the top plate. Physical dimensions are shown left.

The housing of the detector is connected to ground return.

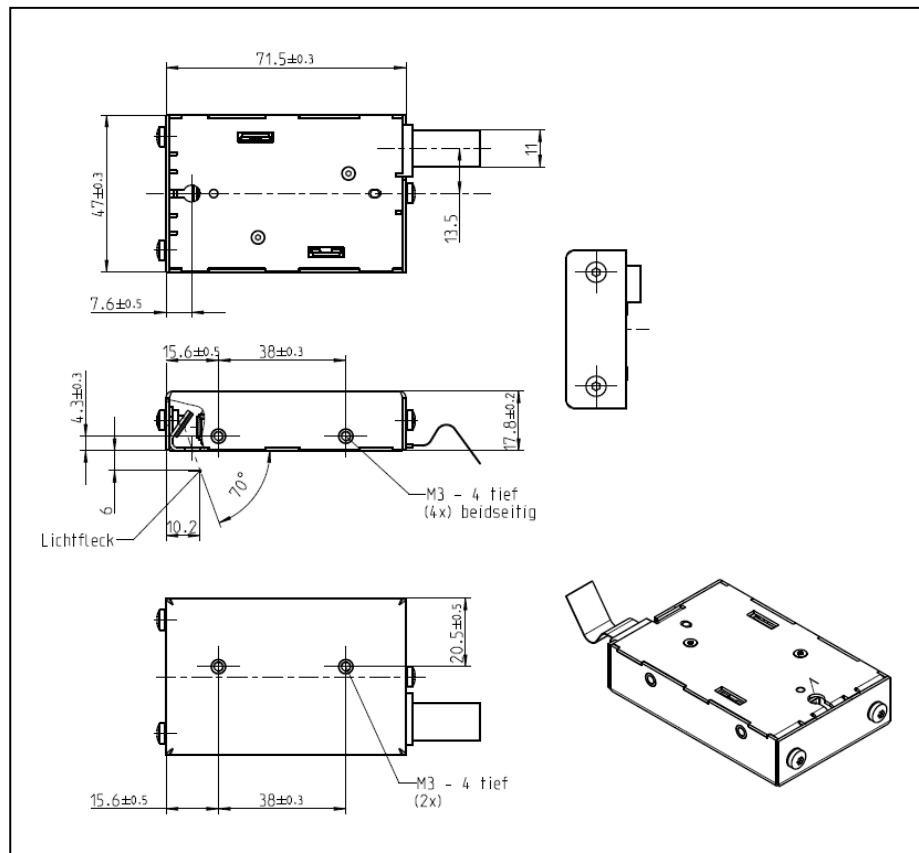

ESMO35-MB-xxxx Detector Dimensions.

5 Operating Conditions

While using the , please note the following:

- Surrounding Temperature: +10 °C to +40 °C
- Transport Temperature: -45 °C to +65 °C
- Relative Humidity: 20% to 70% rel. humidity

5.1 Environment

If you plan to use the device in a working environment prone to dust and dirt, you will need to clean the device regularly. For cleaning, use a damp cloth. For more persistent stains, it is also possible to clean the surface with a cloth moistened with pure alcohol (isopropanol or ethanol). Avoid the use of aggressive solvents such as acetone.



Do not expose the device to direct sunlight



Protect the device from high humidity and contact with liquids



Do not expose the device to excessive heat



Do not expose the device to strong electromagnetic radiation

5.2 Safety Instructions



Tip!

While connecting an external trigger signal or external power supply, the maximum permissible power should not be exceeded (see section 2.2)



Danger!

Do not operate the device in environments where explosions are possible.



Tip!

The device may heat up in normal operating mode.



Danger!

Do not use device on patients.



Tip!

Never touch the detector's optics.



Warning!

Do not immerse the device in water.



Danger!

Do not look directly into the optics! Detectors emit strong light radiation that can cause permanent damage to the eye.



Warning!

The device should only be connected and disconnected in power-off mode.

6 Contents of the FLUO SENS integrated Package

Carefully unpack the contents of the package and check that all components (shown left) are contained therein. For claims, please contact customer service.

The contains the following components:

- The FLUO SENS integrated

6.1 Start up

The is ready for use upon delivery.

6.2 Mounting

The housing possesses two M3 threads on both long sides for mounting purposes.

The positions of the threads are given in the drawings in chapter 4. Please note that the maximum permissible depth of the fixing screws is 4mm. Longer screw threads can cause permanent damage to the detector.

In addition the ESMO40 - series detectors can be clamped using the Ø8mm optics nozzle.

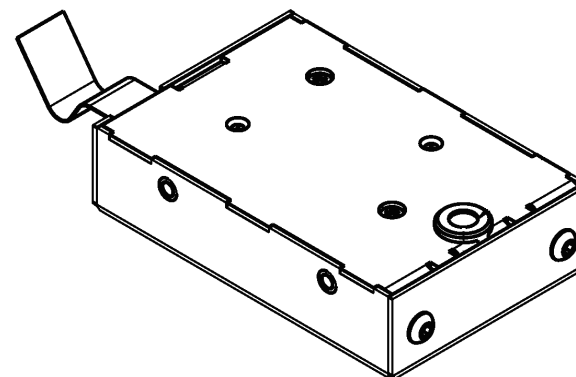

The FLUO SENS integrated



Caution!

*The maximum permissible depth of the thread is
4mm.*

7 Establishing Connection with a Computer

7.1 Connecting a Single Detector

In order to connect the detector, a 10way flex cable is attached at the backside of the detector. The function is to transfer power as well as communication

A more detailed description of the pin assignment can be found in section 3.



Tip!

The RS485 version can also be connected to a conventional RS232 or USB interface via an interface converter.

This method can be utilized for multiple measurements of microtitre plates.



Tip!

When multiple detectors are interconnected, the driver load and the pulse-like current intake of the LEDs must be taken into account.

7.2 Connecting Multiple Detectors

Up to 16 RS485 or TTL detectors can be attached parallel to a master. The MODBUS specifications allow up to 255 devices, however the built-in drivers limit the number to 64 for RS485 and 16 for TTL versions.

The MODBUS address for each device must be set at a value between 1 and 254 before being connected.

Each attached detector can be simultaneously prompted to carry out a fluorescence measurement by using the Start command in tandem with the MODBUS address „255“ or the external trigger input.

8 Instructions for Usage in Compliance with EMC-Directive 89/338 EWG

In use, the is not intended to be operated independently and is exclusively manufactured for further use in EMC-competent industries and companies

The detectors may only be used by trained personnel who are qualified to carry out installation, operation and maintenance of the devices in accordance with any relevant regulations.

The user must insure that the devices and the accompanying components and equipment are mounted and connected in compliance with local legal and technical regulations. In Germany, this includes the VDE and Employer's Liability Insurance Association regulations, as well as the stipulations of the EMC directives

8.1 EMC-Safety Precautions

In the case of increased radiation rates in terms of the EMC law (EMVG), the radiation can be suppressed by routing the connecting cable through a suitable ferrite core, for example Würth Elektronik 7427221.

Additionally, the FLUO SENS Integrated housing can be earthed to ground using one of the mounting threads.

8.2 Switching on the Device

Immediately after plugging in the interface plug and the power source, the is ready to use. No further procedure must be carried out.

8.3 Switching off the Device

To switch off the device, simply remove it from the power source. Any parameters which are stored in the device will not be lost.

9 Operation

is configured and operated exclusively via MODBUS-ASCII commands. No further operation elements are necessary.

9.1 MODBUS-ASCII

The MODBUS Protocol was developed and released by the company MODICON in the early 1980s. It is primarily employed in the area of process automation. Because it is an open protocol and, if nothing else, its simple structure, it is widely used. In the meantime, the MODBUS-IDA Organization is responsible for the maintenance and continuing development of the protocol. Numerous documents can be obtained.

MODBUS is based on a master/slave system. The master is a superordinate controller, for example a PC or a programmable controller. The MODBUS Controllers in the FLUO SENS integrated are slave devices.

There are no bus conflicts, since only a single node sends at a time. The master requests communication. This request can be directed to a specific node or sent out as a message to all nodes. The nodes receive the request and send, independently of the type of request, a reply to the master.

MODBUS communication is implemented as follows:

- MODBUS serial communication via serial interfaces such as RS232, RS485
- MODBUS ASCII codes the data using ASC-II character set in the form of legible character chains

MODBUS works according to the Master/Slave principle. A master can communicate with one or more slaves. Only slaves explicitly permitted by the Master can return data to the Master.

The protocol supports both binary and 16-bit values, which are read in block-form by the Master. Neither quality recognition, nor time stamps are supported.

10 Configuring a MODBUS-Protocol

The MODBUS-ASCII Protocol is integrated into the . All protocols are coded in hexadecimal values, represented by readable ASCII characters. Only the characters 0-9 and A-F are used for coding purposes. For each byte of information, two bytes are required for the communication, due to the fact that in the hexadecimal system, only 4 bytes of information can be transmitted.

- Protocol Start: Character “:” (colon)
- Coding: hexadecimal, ASCII characters 0-9, A-F
- Serial Interface: 1 start bit, 8 data bits, no parity, 1 stop bit
- Check sum: Longitudinal Redundancy Check (LRC)
- Protocol End: CRLF
- Baud rate: 57600 (standard value)

Start	Address	Function	Value	LRC Check	End
1 character	2 characters	2 characters	N characters	2 characters	2 characters CR LF



Tip!

Detectors always respond to Write/Read Access with MODBUS address 0. This is useful, for example, if the address in register 165 has been altered.

10.1 Longitudinal Redundancy Check (LRC)

The Longitudinal Redundancy Check (LRC) field is one byte, containing an 8-bit binary value. The LRC value is calculated by the transmitting device, which appends the LRC to the message. The receiving device recalculates an LRC during receipt of the message, and compares the calculated value to the actual value it received in the LRC field. If the two values are not equal, an error results. The LRC is calculated by adding together successive 8-bit bytes in the message, discarding any carries, and then two's complementing the result. The LRC is an 8-bit field, therefore each new addition of a character that would result in a value higher than 255 decimal simply 'rolls over' the field's value through zero. Because there is no ninth bit, the carry is discarded automatically. A procedure for generating an LRC is:

1. Add all bytes in the message, excluding the starting 'colon' and ending CRLF. Add them into an 8-bit field, so that carries will be discarded.
2. Now built the two's-complement – the result is the LRC byte.

10.2 MODBUS Function Codes

The supports the MODBUS-ASCII Protocol with the function codes 3 and 16. The data points are handled via register addressing. A register consists of 16 bits. Measurement values are transferred as long-values and consist of 2 registers. In this manner, data points can be used directly without decimal points.

- Function Code 03: Reads up to 16 16bit-registers
- Function Code 06: Provides write access to 16bit-registers

10.3 Function-Code 03: Reading up to 16 16bit-Registers

This protocol reads up to 16 16bit-registers from a connected device.

The following example reads 2 registers (32bit) from the addresses 235 and 236.

The connected device was given the MODBUS address 9.

Request	Response
Field Name/Value (Hex)	Field Name/Value (Hex)
Start Frame	Start Frame
Slave Address 09	Slave 09
Function code 03	Function code 03
Start Register Hi 00	Number of Bytes 04
Start Register Lo EB	Value Hi (Register 235) 00
Number of Registers Hi 00	Value Lo (Register 235) 00
Number of Registers Lo 02	Value Hi (Register 236) 00
LRC 07	LRC F1
End Frame CRLF	End Frame CRLF

10.4 Function-Code 06: Writing of 16 16bit-Registers

This protocol writes a 16bit-register to a connected device.

The following example writes 1 register (16bit) on the address 235.

Request	Response
Field Name/Value (Hex)	Field Name/Value (Hex)
Start Frame	Start Frame
Slave Address 09	Slave Address 09
Function code 06	Function code 06
Start Register Hi 00	Register Address Hi 00
Start Register Lo EB	Register Address Lo EB
Value Hi (Register 235) 00	Value Hi 00
Value Lo (Register 235) 00	Value Lo 02
LRC 06	LRC 04
End Frame CRLF	End Frame CRLF

10.5 Register Assignment

For communication purposes, the MODBUS-ASCII Protocol has been installed in the . The following sections describe the storage allocation.

10.5.1 Definitions

D1 = Measurement Values from Detection Channel 1
 D2 = Measurement Values from Detection Channel 2
 E1 = Excitation Channel 1
 E2 = Excitation Channel 2

Cycles Number of measurements to be carried out after the Start command has been sent.

Cycle Time Interval in seconds between two measurements within a cycle.

- Start mode**
- **By command:** If a „1“ has been written in location 512, the measurement will be started
 - **Trigger single:** Measurement is started by sending the “Start Method Command”. One data sequence is taken for each h/w trigger until the method is finished.
 - **Trigger measurement:** Measurement is started by sending the “Start Method Command”, all values are taken after one h/w trigger
 - **Auto command:** Measurement is started at power on, the stored method will run once
 - **Auto trigger single:** Measurement is started at power on, one value is taken for every h/w trigger until the method is finished
 - **Auto trigger measurement:** Measurement is started at power on, all values are taken after one h/w trigger

Method Type	E1D2: Emission on channel 1, detection on channel 2 S_E1D1: Scope mode E1D1. The detector records 1500 data points and saves them in registers 513-3513.
Dark Signal Type	No dark signal (LED off): No dark signals recorded Dark signal once: At the beginning of a measurement cycle, one dark signal will be recorded. Dark signal every: At the beginning of a measurement cycle, dark signal will be recorded for every measurement value .
Average	Number of measurement values used to calculate an average.
LED Mode	Toggle: LED controlled by the detector Manual: LED must be set manually before measurement is starting
Trigger Delay	Wait time in ms before a measurement is started via trigger impulse
On Delay LEDx	The detector waits for “On Delay LEDx” ms after the LEDx has been turned on before a measurement is carried out.
Off Delay LEDx	The detector waits for “On Delay LEDx” ms after the LEDx has been turned off before a dark signal measurement is carried out.
LEDx Power Default	“LEDx ” standard LED set value for LED x
LEDx Power Max	Maximum allowed set value for “LEDx Power”
LEDx Power Min	Minimum allowed set value for “LEDx Power”

10.6 FLUO SENS integrated Memory Allocation

Wort Adresse	Byte 0	Byte1	Byte2	Byte3
0	Cycles [0 - 65535]		Cycletime [s] [0 - 65535]	
2	Startmode * [0 - by command 1 - trigger single 2 - trigger measurement 3 - auto command 4 - auto trigger single 5 - auto trigger measurement]	not used	Method Type * [1 - E1D1 2 - E1D2 3 - E2D2 4 - E1D1+E1D2 5 - E1D1+E2D2 6 - E1D2+E2D2 7 - E1D1+E1D2+E2D2 8 - S_E1D1 9 - S_E1D2 10 - S_E2D2]	not used
4	Dark Signal Type * [0 - no dark signal 1 - dark once 2 - dark every]	not used	Average * [1 - 255]	not used
6	Led Mode * [0 - toggle 1 - manual]	not used	Trigger Delay [ms] [0 - 65535]	
8	E1D1 Factor			
10	E1D2 Factor			
12	E2D2 Factor			
14	E1D1 Offset			
16	E1D2 Offset			
18	E2D2 Offset			
20	On Delay LED1 [ms] [0 - 65535]		On Delay LED2 [ms] [0 - 65535]	
22	Off Delay LED1 [ms] [0 - 65535]		Off Delay LED2 [ms] [0 - 65535]	
24	LED1 Current * [0 - 255]	not used	LED2 Current * [0 - 255]	not used
26	Led1 Current Default * [0 - 255]	not used	LED2 Current Default * [0 - 255]	not used
28	LED1 Current Max * [0 - 255]	not used	LED2 Current Max * [0 - 255]	not used
30	LED1 Current Min * [0 - 255]	not used	LED2 Current Min * [0 - 255]	not used
32	ADC Sampling * [100 - 500]		not used	

Wort Adresse	Byte 0	Byte1	Byte2	Byte3
128	Board Name			
130				
132				
134				
136				
138				
140				
142	Board Serialnumber			
144				
146				
148	Board ID			
150				
152				
154				
156	Hardware Revision			
158				
160	Optic Revision			
162				
164	Board Type [0 - all 1 - E1D1 2 - E1D1 + E1D2 3 - E1D1+E1D2+E2D2 4 - E1D2 5 - E2D2 6 - E1D1+E2D2 7 - E1D2+E2D2]	not used	Modbus Address [0 - 255]	not used
166	Baudrate [57600, 38400, 19200, 9600, 4800, 2400]			

Wort Adresse	Byte 0	Byte1	Byte2	Byte3
256	Ticket			
258	Temperatur [Faktor to °C = ((Counts * 2500 / 8388607) - 54.3) / 0.205]			
260	On Value 1 [Faktor to mV = Counts * 2500 / 8388607]			
262	On Value 2 [Faktor to mV = Counts * 2500 / 8388607]			
264	On Value 3 [Faktor to mV = Counts * 2500 / 8388607]			
266	Off Value 1 [Faktor to mV = Counts * 2500 / 8388607]			
268	Off Value 2 [Faktor to mV = Counts * 2500 / 8388607]			
270	Off Value 3 [Faktor to mV = Counts * 2500 / 8388607]			
384	Software Version			
386				
388				
390				
392				
394				
396				
398				
400	User defined value 1 (stored in NVRam)	User defined value 2 (stored in NVRam)		
...		
510	User defined value 111 (stored in NVRam)	User defined value 112 (stored in NVRam)		

Wort Adresse	Byte 0	Byte1	Byte2	Byte3
Write Access				
512	Start Method Command		Stop Method Command	
514	LED1 On/Off Command		LED2 On/Off Command	
516	Start Autozero Command		Save actual(0) or default(1) parameters	
518	Save default parameters to NVRam		Setup ADC	
Read Access				
512	Number of saved datapoints			
513	Datapoint 1 [Faktor to mV = Counts * 2500 / 8388607]			
515	Datapoint 2 [Faktor to mV = Counts * 2500 / 8388607]			
...	...			
3513	Datapoint 1500 [Faktor to mV = Counts * 2500 / 8388607]			

Special:

Modbus address 255 is the broadcast address, the device doesn't send a response to this request.

Remark:

For byte parameters in bytes 0 or 2 (like Modbus Adress...) the given values written to the detector must be multiplied by 256.

Example:

Set Modbus Address to 2 you have to write $2 * 256 = 512$ to the detector word address 164.

Registers 400 to 511 are general purpose registers for storage of any user data (available in firmware version 1.46, dated 19.12.2011 and higher).

10.7 Examples

10.8 Reading “Version”

Request: ":0003018000106c"
 Response:
 ":00032056312E303328363429204F6374203137
 2032303037009000C6E0FD3395E0FC7408"
 Interpretation of characters: V1.03(64) Oct 2007

10.9 Reading “Temperature”

Request: ":000301020002f8"
 Response: ":00030400033ACBF1"
 Integer Interpretation: 0x0033ACB = 211659 counts
 Conversion counts - °C: ((counts*0,000298026) – 54,3) / 0,205
 211659 counts = 42,8°C

10.10 Reading “Method Type”

Request: ":000300030001f9"
 Response: ":0003020100FA"
 Interpretation of characters: 0x01 = 1 = E1D1

10.11 Reading measurement value “On Value 1”

Request: ":000301040002f6"
 Response: ":000304001C5A364D"
 Integer Interpretation: 001C5A36h = 1858102 counts

Conversion counts - mV:counts * 0.000298026
 1858102 Counts = 553,76mV

10.12 Setting “Start Method Command”

Request: ":000602000001F7"
 Response: ":000602000001F7"

10.13 “Start Method Command” and Reading Data

The detector starts a measurement when a „1“ is written in register 512.

The data counter in the registers 256..257 (ticket) is increased after each measurement value has been written in the respective register (On Value 1...3, Off Value 1...3).

The measurement values must be read cyclically from the respective registers if the ticket counter has been altered. With cyclical readouts, the current measurement values will each be overwritten by the latest valid measurement values.

11 Controlling via Hyper Terminal

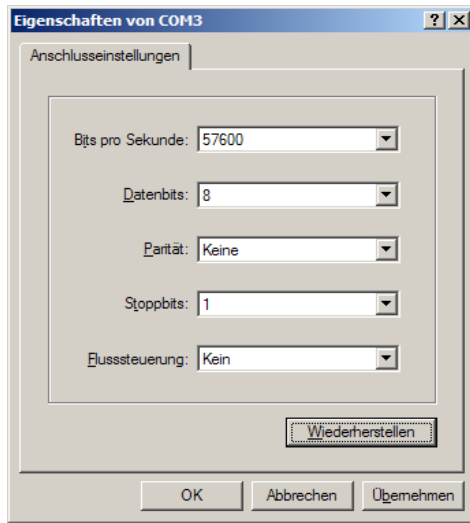

Setting up parameters in Microsoft Windows® Hyper Terminal

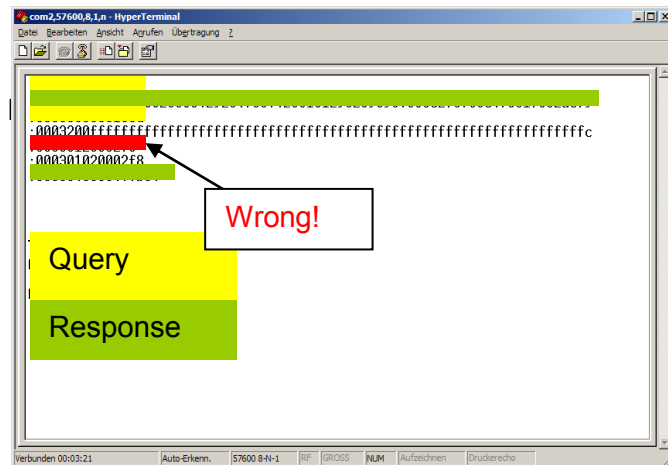

12 The FL Digital Program

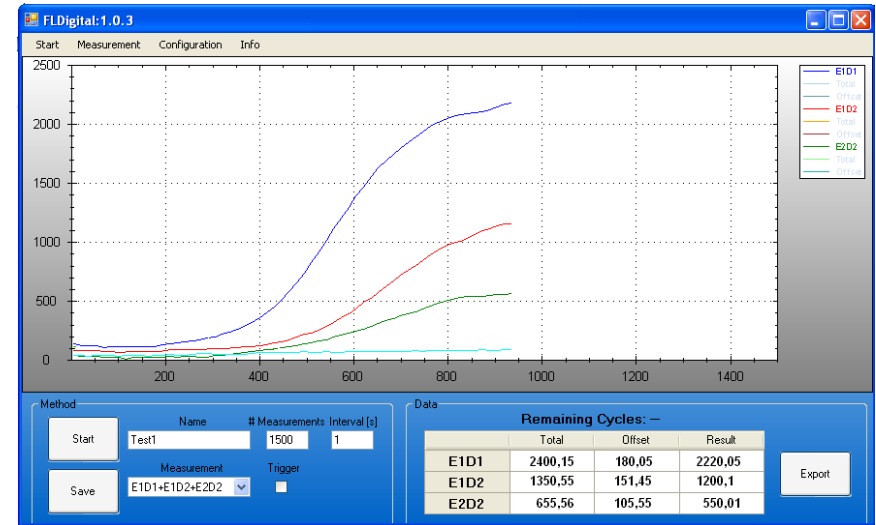

The FL Digital program allows the user to collect and display data from the FLUO SENS integrated. Instrument sensitivity parameters can be setup and saved to the FLUO SENS integrated, data can be stored on disk. A detailed description of the FL Digital program is given in a separate manual,

13 Troubleshooting and Problem Solving

This chapter is intended for users and programmers. The descriptions shall help users to solve problems and correct errors in normal operation of the .

- Error:** No response to MODBUS requests.
- Cause:** MODBUS commands are being incorrectly sent.
- Correction:** Implement the MODBUS-Protocols according to standard. See example in section 10.7.
-
- Error:** No response to MODBUS requests.
- Cause:** Incorrect master interface settings.
- Correction:** Set the master serial interface settings to 57600, 8, 1, n. See test example in section 10.7.
-
- Error:** No response to MODBUS requests.
- Cause:** Incorrect MODBUS Address is being used.
- Correction:** Try communication with MODBUS address „0“. Test example in section 10.7.

- Error:** No response to MODBUS requests.
- Cause:** Checksum has been incorrectly calculated
- Correction:** Calculate Checksum according to LRC (See section 12.1). See test example from section 13.
-
- Error:** No power input.
- Cause:** Power supply not connected.
- Correction:** Check pin assignment in section 3, test and make any necessary alterations.
-
- Error:** No power input.
- Cause:** External power source has not been switched on.
- Correction:** Switch on power source.
-
- Error:** No Communication
- Cause:** Reset-wire (see section 3) is grounded.
- Correction:** Examine the level of the reset wire and, if necessary, connect via a resistor to +5V.

14 Maintenance and Care

This chapter is intended for qualified users with maintenance responsibilities. The following description will introduce users to the necessary maintenance and care tasks connected with operation of the .



Tip!

If using the in working environments with high-levels of dirt build up, the device should be regularly cleaned. To clean the device, please use a damp cloth. For more stubborn dirt stains, the surface can also be cleaned with a cloth dipped in pure alcohol (Isopropanol oder Ethanol). Avoid the use of aggressive cleansers such as Aceton. No detergents should enter the housing of the .



Tip!

If using the in working environments near or connected to vibrating machinery, it is necessary to regularly check the sensor cables to ensure secure contact.



Tip!

If the is operated in high temperature environments, the measurement values can deviate somewhat from the real values. In this case, calibrate the device beforehand under the same conditions. Follow the operating instructions in section.

15 Warranty and Customer Services

Devices in the series are highly developed electronic devices. In the interest of safety, the manufacturers of this device reserve the exclusive right to carry out all repairs themselves.

In case of a defective device, please do not attempt to repair the device yourself. There are no self-maintenance parts within the device. In case of any possible defects, please contact QIAGEN Lake Constance GmbH (address given on page 2).

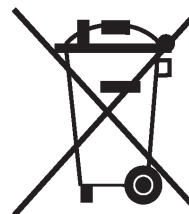

Packaging can be reused or recycled. Please separate metal, plastic, electrical parts, circuit boards into the respective recycling bins, following local recycling procedures.

For product or customer service requests, please contact QIAGEN Lake Constance GmbH (address given on page 2).

15.1 Liability for Defects

The warranty period is based on statutory provisions and is usually 24 months. In the case of pre-used equipment, liability for defects and warranty shall be excluded. If instructions given by QIAGEN Lake Constance GmbH with respect to storage, installation and handling of the products are not followed, or if changes are made to the product, parts are replaced or consumable items are used which do not comply with the original specifications, any warranty rights are forfeited unless the business partner is able to refute any assertion that any of these circumstances has caused the deficiency. Defects, incorrect deliveries, quantities or transport damage are to be notified without delay by the business partner of QIAGEN Lake Constance GmbH in writing or by fax (in case of defects that can be identified immediately), otherwise within 2 weeks of receipt of the products at the place of destination, by clearly describing the defect. In this respect it is necessary that the business partner properly fulfills his obligations of investigation and notification in accordance with Article 377 of the Commercial Code. QIAGEN Lake Constance GmbH shall be notified of any defects, which cannot be detected within a reasonable timeframe, immediately upon their detection. If the business partner notifies QIAGEN Lake Constance GmbH that the products are defective, QIAGEN Lake Constance GmbH will require return of the defective products for repair or replacement at the discretion of QIAGEN Lake Constance GmbH. Transportation of the defective product is to be insured by the business partner of QIAGEN Lake Constance GmbH. If return to factory and rework fails at least two times, or cannot be reasonably expected from QIAGEN Lake Constance GmbH, the business partner has the option to demand a reduction in price or withdraw from the contract. The same shall apply if replacement of the product fails or cannot be reasonably expected from QIAGEN Lake Constance GmbH. Withdrawal from the contract shall be allowed only if the reduction in value of the product, or reduction in its suitability for use in accordance with the contract is deemed to be significant. In this case, warranty costs will still be applicable.

15.2 Warranty

As a rule, the statutory 24-month manufacturer warranty shall apply for hardware and software products not produced by QIAGEN Lake Constance GmbH. Furthermore, warranty for these products will only be provided on condition that the warranty case is recognized and confirmed by the manufacturer or the subcontractor of QIAGEN Lake Constance GmbH. QIAGEN Lake Constance GmbH will provide warranty for products of QIAGEN Lake Constance GmbH for at least 24 months. Consumable parts, including rechargeable batteries, will be covered by a specific warranty period. If QIAGEN Lake Constance GmbH gives the business partner warranty beyond the warranty period mentioned above, QIAGEN Lake Constance GmbH will reserve the right to repair or replace the defective part. The place of fulfillment of this warranty shall be the company address stated below. If The product is found to be defective despite our rigorous quality control systems, please contact us at the address given on page 2:

Upon receipt of your notification of claim we will promptly send you a RMA form. In addition to the RMA number, this document includes space for you to describe the nature of the problem. The RMA number is for warranty claims and provides transparency in the transaction, allowing us to process the claim as quickly as possible. After filling out the form, please return the form and the defective product freight collect to the above address. We will repair or replace the product and return it to you as fast as possible. Please be aware that it may take several days to process this transaction.



Products are subject to the
quality standards in
compliance / accordance
with DIN ISO 9001.

QIAGEN Lake Constance GmbH
Jacques-Schiesser-Strasse 3
D-78333 Stockach

Germany

Website: www.qiagen.com

Email: info@qiagen.com