



PSoC® Creator™

Project Datasheet for Design01

Creation Time: 09/27/2022 09:38:40

User: SHUVRA\Avinash

Project: Design01

Tool: PSoC Creator 4.2

Cypress Semiconductor
198 Champion Court
San Jose, CA 95134-1709
Phone (USA): 800.858.1810
Phone (Intl): 408.943.2600
<http://www.cypress.com>

Copyright

Copyright © 2022 Cypress Semiconductor Corporation. All rights reserved. Any design information or characteristics specifically provided by our customer or other third party inputs contained in this document are not intended to be claimed under Cypress's copyright.

Trademarks

PSoC and CapSense are registered trademarks of Cypress Semiconductor Corporation. PSoC Creator is a trademark of Cypress Semiconductor Corporation. All other trademarks or registered trademarks referenced herein are the property of their respective owners.

Philips I2C Patent Rights

Purchase of I2C components from Cypress or one of its sublicensed Associated Companies conveys a license under the Philips I2C Patent Rights to use these components in an I2C system, provided that the system conforms to the I2C Standard Specification as defined by Philips. As from October 1st, 2006 Philips Semiconductors has a new trade name, NXP Semiconductors.

Disclaimer

CYPRESS MAKES NO WARRANTY OF ANY KIND, EXPRESS OR IMPLIED, WITH REGARD TO THIS MATERIAL, INCLUDING, BUT NOT LIMITED TO, THE IMPLIED WARRANTIES OF MERCHANTABILITY AND FITNESS FOR A PARTICULAR PURPOSE. While reasonable precautions have been taken, Cypress assumes no responsibility for any errors that may appear in this document. Cypress reserves the right to make changes without further notice to the materials described herein. Cypress does not assume any liability arising out of the application or use of any product or circuit described herein. Cypress does not authorize its products for use as critical components in life support systems where a malfunction or failure may reasonably be expected to result in significant injury to the user. The inclusion of a Cypress product in a life support systems application implies that the manufacturer assumes all risk of such use and in doing so indemnifies Cypress against all charges.

Flash Code Protection

Cypress products meet the specifications contained in their particular Cypress PSoC Datasheets. Cypress believes that its family of PSoC products is one of the most secure families of its kind on the market today, regardless of how they are used. There may be methods, unknown to Cypress, that can breach the code protection features. Any of these methods, to our knowledge, would be dishonest and possibly illegal. Neither Cypress nor any other semiconductor manufacturer can guarantee the security of their code. Code protection does not mean that we are guaranteeing the product as 'unbreakable.'

Cypress is willing to work with the customer who is concerned about the integrity of their code. Code protection is constantly evolving. We at Cypress are committed to continuously improving the code protection features of our products.

Table of Contents

1 Overview.....	1
2 Pins.....	3
2.1 Hardware Pins.....	4
2.2 Hardware Ports.....	6
2.3 Software Pins.....	8
3 System Settings.....	10
3.1 System Configuration.....	10
3.2 System Debug Settings.....	10
3.3 System Operating Conditions.....	10
4 Clocks.....	11
4.1 System Clocks.....	12
4.2 Local and Design Wide Clocks.....	12
5 Interrupts and DMAs.....	14
5.1 Interrupts.....	14
5.2 DMAs.....	14
6 Flash Memory.....	15
7 Design Contents.....	16
7.1 Schematic Sheet: Potentiostat.....	16
8 Components.....	17
8.1 Component type: ADC_DeISig [v3.30].....	17
8.1.1 Instance ADC.....	17
8.2 Component type: CharLCD [v2.20].....	19
8.2.1 Instance LCD.....	19
8.3 Component type: DVDAC [v2.10].....	19
8.3.1 Instance DVDAC.....	19
8.4 Component type: OpAmp [v1.90].....	20
8.4.1 Instance OPAMP.....	20
8.5 Component type: TIA [v2.0].....	20
8.5.1 Instance TIA.....	20
8.6 Component type: Timer [v2.80].....	20
8.6.1 Instance TIMER.....	20
8.7 Component type: USBFS [v3.20].....	21
8.7.1 Instance USB.....	22
8.8 Component type: VDAC8 [v1.90].....	24
8.8.1 Instance VDAC_REF.....	24
9 Other Resources.....	25

1 Overview

The Cypress PSoC 5 is a family of 32-bit devices with the following characteristics:

- High-performance 32-bit ARM Cortex-M3 core with a nested vectored interrupt controller (NVIC) and a high-performance DMA controller
- Digital system that includes configurable Universal Digital Blocks (UDBs) and specific function peripherals, such as USB, I2C and SPI
- Analog subsystem that includes 20-bit Delta Sigma converters (ADC), SAR ADCs, 8-bit DACs that can be configured for 12-bit operation, comparators, op amps and configurable switched capacitor (SC) and continuous time (CT) blocks to create PGAs, TIAs, mixers, and more
- Several types of memory elements, including SRAM, flash, and EEPROM
- Programming and debug system through JTAG, serial wire debug (SWD), and single wire viewer (SWV)
- Flexible routing to all pins

Figure 1 shows the major components of a typical [CY8C58LP](#) series member PSoC 5LP device. For details on all the systems listed above, please refer to the [PSoC 5LP Technical Reference Manual](#).

Figure 1. CY8C58LP Device Series Block Diagram

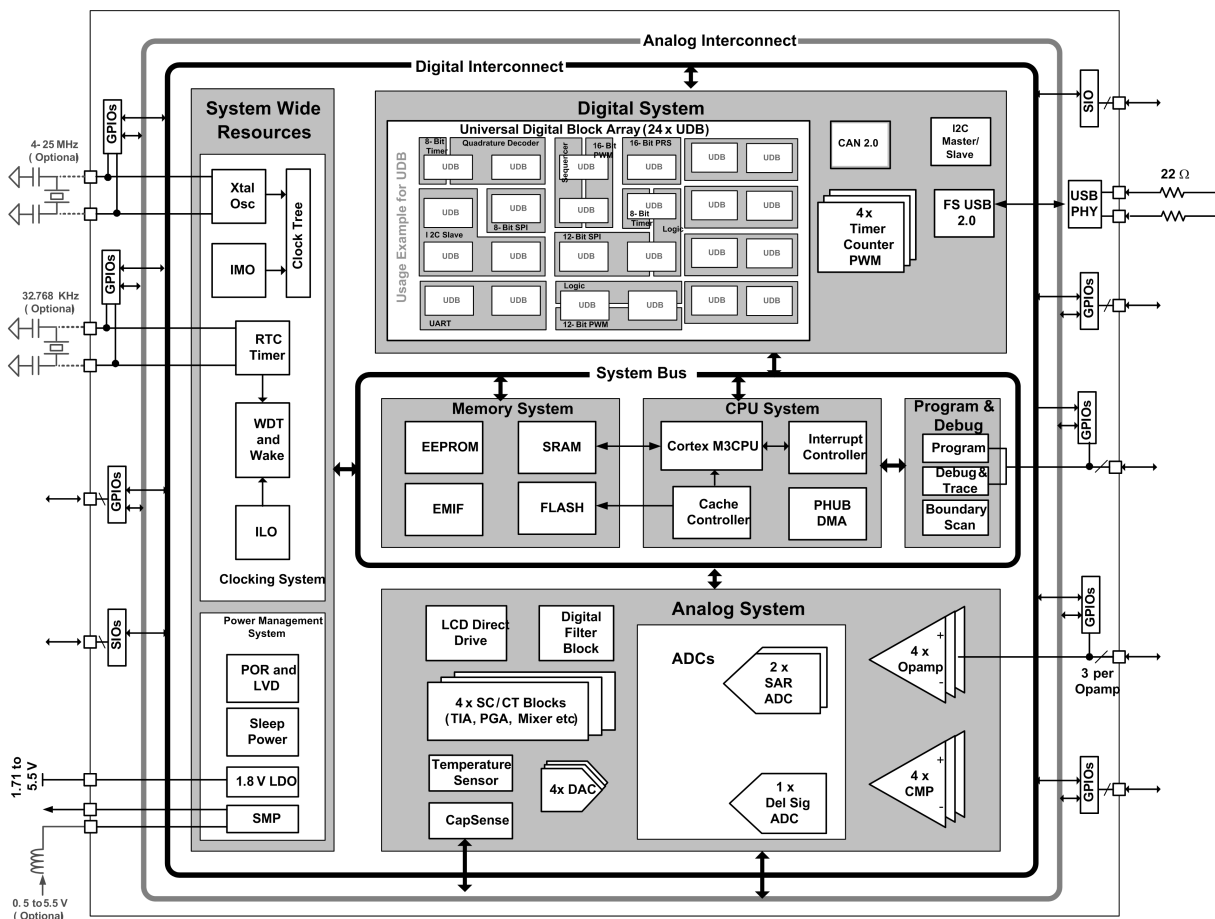

Table 1 lists the key characteristics of this device.

Table 1. Device Characteristics

Name	Value
Part Number	CY8C5888LTI-LP097
Package Name	68-QFN
Family	PSoC 5LP
Series	CY8C58LP
Max CPU speed (MHz)	0
Flash size (kB)	256
SRAM size (kB)	64
EEPROM size (bytes)	2048
Vdd range (V)	1.71 to 5.5
Automotive qualified	No (Industrial Grade Only)
Temp range (Celsius)	-40 to 85
JTAG ID	0x2E161069

NOTE: The CPU speed noted above is the maximum available speed. The CPU is clocked by Bus Clock, listed in the [System Clocks](#) section below.

Table 2 lists the device resources that this design uses:

Table 2. Device Resources

Resource Type	Used	Free	Max	% Used
Digital Clocks	2	6	8	25.00 %
Analog Clocks	1	3	4	25.00 %
CapSense Buffers	0	2	2	0.00 %
Digital Filter Block	0	1	1	0.00 %
Interrupts	9	23	32	28.13 %
IO	20	28	48	41.67 %
Segment LCD	0	1	1	0.00 %
CAN 2.0b	0	1	1	0.00 %
I2C	0	1	1	0.00 %
USB	1	0	1	100.00 %
DMA Channels	1	23	24	4.17 %
Timer	0	4	4	0.00 %
UDB				
Macrocells	4	188	192	2.08 %
Unique P-terms	2	382	384	0.52 %
Total P-terms	3			
Datapath Cells	3	21	24	12.50 %
Status Cells	1	23	24	4.17 %
StatusI Registers	1			
Control Cells	1	23	24	4.17 %
Control Registers	1			
Opamp	1	3	4	25.00 %
Comparator	0	4	4	0.00 %
Delta-Sigma ADC	1	0	1	100.00 %
LPF	0	2	2	0.00 %
SAR ADC	0	2	2	0.00 %
Analog (SC/CT) Blocks	1	3	4	25.00 %
DAC				
VIDAC	2	2	4	50.00 %

2 Pins

Figure 2 shows the pin layout of this device.

Figure 2. Device Pin Layout

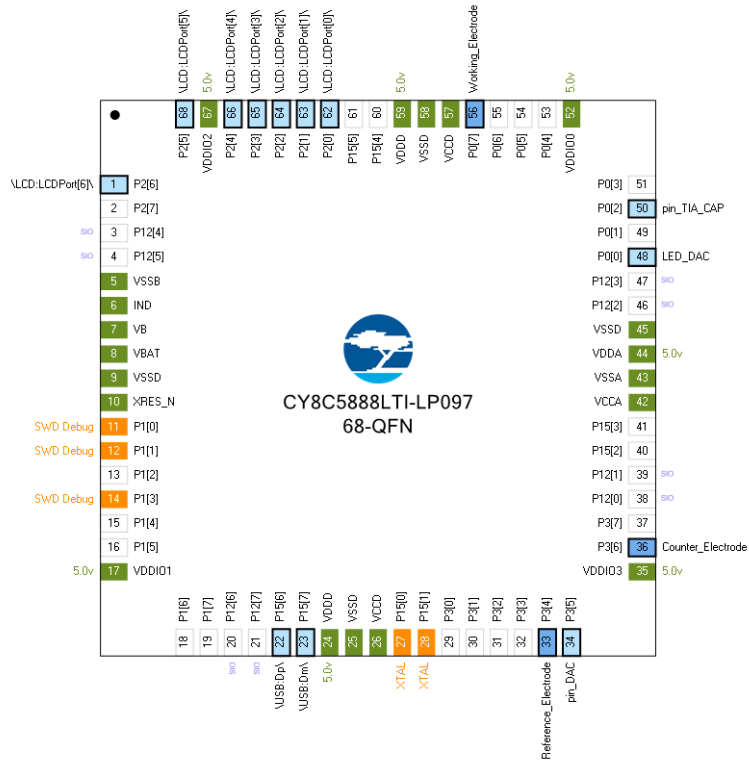

2.1 Hardware Pins

Table 3 contains information about the pins on this device in device pin order. (No connection ["n/c"] pins have been omitted.)

Table 3. Device Pins

Pin	Port	Name	Type	Drive Mode	Reset State
1	P2[6]	\LCD:LCDPort[6]\	Software In/Out	Strong drive	HiZ Analog Unb
2	P2[7]	GPIO [unused]			HiZ Analog Unb
3	P12[4]	SIO [unused]			HiZ Analog Unb
4	P12[5]	SIO [unused]			HiZ Analog Unb
5	VSSB	VSSB	Dedicated		
6	IND	IND	Dedicated		
7	VB	VB	Dedicated		
8	VBAT	VBAT	Dedicated		
9	VSSD	VSSD	Power		
10	XRES_N	XRES_N	Dedicated		
11	P1[0]	Debug:SWD_IO	Reserved		
12	P1[1]	Debug:SWD_CK	Reserved		
13	P1[2]	GPIO [unused]			HiZ Analog Unb
14	P1[3]	Debug:SWV	Reserved		
15	P1[4]	GPIO [unused]			HiZ Analog Unb
16	P1[5]	GPIO [unused]			HiZ Analog Unb
17	VDDIO1	VDDIO1	Power		
18	P1[6]	GPIO [unused]			HiZ Analog Unb
19	P1[7]	GPIO [unused]			HiZ Analog Unb
20	P12[6]	SIO [unused]			HiZ Analog Unb
21	P12[7]	SIO [unused]			HiZ Analog Unb
22	P15[6]	\USB:Dp\	Analog	HiZ analog	HiZ Analog Unb
23	P15[7]	\USB:Dm\	Analog	HiZ analog	HiZ Analog Unb
24	VDDD	VDDD	Power		
25	VSSD	VSSD	Power		
26	VCCD	VCCD	Power		
27	P15[0]	XTAL:Xi	Reserved		
28	P15[1]	XTAL:Xi	Reserved		
29	P3[0]	GPIO [unused]			HiZ Analog Unb
30	P3[1]	GPIO [unused]			HiZ Analog Unb
31	P3[2]	GPIO [unused]			HiZ Analog Unb
32	P3[3]	GPIO [unused]			HiZ Analog Unb
33	P3[4]	Reference_Electrode	Analog	HiZ analog	HiZ Analog Unb
34	P3[5]	pin_DAC	Analog	HiZ analog	HiZ Analog Unb
35	VDDIO3	VDDIO3	Power		
36	P3[6]	Counter_Electrode	Analog	HiZ analog	HiZ Analog Unb
37	P3[7]	GPIO [unused]			HiZ Analog Unb
38	P12[0]	SIO [unused]			HiZ Analog Unb
39	P12[1]	SIO [unused]			HiZ Analog Unb
40	P15[2]	GPIO [unused]			HiZ Analog Unb
41	P15[3]	GPIO [unused]			HiZ Analog Unb
42	VCCA	VCCA	Power		
43	VSSA	VSSA	Power		
44	VDDA	VDDA	Power		
45	VSSD	VSSD	Power		

Pin	Port	Name	Type	Drive Mode	Reset State
46	P12[2]	SIO [unused]			HiZ Analog Unb
47	P12[3]	SIO [unused]			HiZ Analog Unb
48	P0[0]	LED_DAC	Software In/Out	Strong drive	HiZ Analog Unb
49	P0[1]	GPIO [unused]			HiZ Analog Unb
50	P0[2]	pin_TIA_CAP	Analog	HiZ analog	HiZ Analog Unb
51	P0[3]	GPIO [unused]			HiZ Analog Unb
52	VDDIO0	VDDIO0	Power		
53	P0[4]	GPIO [unused]			HiZ Analog Unb
54	P0[5]	GPIO [unused]			HiZ Analog Unb
55	P0[6]	GPIO [unused]			HiZ Analog Unb
56	P0[7]	Working_Electrode	Analog	HiZ analog	HiZ Analog Unb
57	VCCD	VCCD	Power		
58	VSSD	VSSD	Power		
59	VDDD	VDDD	Power		
60	P15[4]	GPIO [unused]			HiZ Analog Unb
61	P15[5]	GPIO [unused]			HiZ Analog Unb
62	P2[0]	\\LCD:LCDPort[0]\\	Software In/Out	Strong drive	HiZ Analog Unb
63	P2[1]	\\LCD:LCDPort[1]\\	Software In/Out	Strong drive	HiZ Analog Unb
64	P2[2]	\\LCD:LCDPort[2]\\	Software In/Out	Strong drive	HiZ Analog Unb
65	P2[3]	\\LCD:LCDPort[3]\\	Software In/Out	Strong drive	HiZ Analog Unb
66	P2[4]	\\LCD:LCDPort[4]\\	Software In/Out	Strong drive	HiZ Analog Unb
67	VDDIO2	VDDIO2	Power		
68	P2[5]	\\LCD:LCDPort[5]\\	Software In/Out	Strong drive	HiZ Analog Unb

Abbreviations used in Table 3 have the following meanings:

- HiZ Analog Unb = Hi-Z Analog Unbuffered
- HiZ analog = High impedance analog

2.2 Hardware Ports

Table 4 contains information about the pins on this device in device port order. (No connection ["n/c"], power and dedicated pins have been omitted.)

Table 4. Device Ports

Port	Pin	Name	Type	Drive Mode	Reset State
P0[0]	48	LED_DAC	Software In/Out	Strong drive	HiZ Analog Unb
P0[1]	49	GPIO [unused]			HiZ Analog Unb
P0[2]	50	pin_TIA_CAP	Analog	HiZ analog	HiZ Analog Unb
P0[3]	51	GPIO [unused]			HiZ Analog Unb
P0[4]	53	GPIO [unused]			HiZ Analog Unb
P0[5]	54	GPIO [unused]			HiZ Analog Unb
P0[6]	55	GPIO [unused]			HiZ Analog Unb
P0[7]	56	Working_Electrode	Analog	HiZ analog	HiZ Analog Unb
P1[0]	11	Debug:SWD_IO	Reserved		
P1[1]	12	Debug:SWD_CK	Reserved		
P1[2]	13	GPIO [unused]			HiZ Analog Unb
P1[3]	14	Debug:SWV	Reserved		
P1[4]	15	GPIO [unused]			HiZ Analog Unb
P1[5]	16	GPIO [unused]			HiZ Analog Unb
P1[6]	18	GPIO [unused]			HiZ Analog Unb
P1[7]	19	GPIO [unused]			HiZ Analog Unb
P12[0]	38	SIO [unused]			HiZ Analog Unb
P12[1]	39	SIO [unused]			HiZ Analog Unb
P12[2]	46	SIO [unused]			HiZ Analog Unb
P12[3]	47	SIO [unused]			HiZ Analog Unb
P12[4]	3	SIO [unused]			HiZ Analog Unb
P12[5]	4	SIO [unused]			HiZ Analog Unb
P12[6]	20	SIO [unused]			HiZ Analog Unb
P12[7]	21	SIO [unused]			HiZ Analog Unb
P15[0]	27	XTAL:Xi	Reserved		
P15[1]	28	XTAL:Xi	Reserved		
P15[2]	40	GPIO [unused]			HiZ Analog Unb
P15[3]	41	GPIO [unused]			HiZ Analog Unb
P15[4]	60	GPIO [unused]			HiZ Analog Unb
P15[5]	61	GPIO [unused]			HiZ Analog Unb
P15[6]	22	\USB:Dp\	Analog	HiZ analog	HiZ Analog Unb
P15[7]	23	\USB:Dm\	Analog	HiZ analog	HiZ Analog Unb
P2[0]	62	\LCD:LCDPort[0]\	Software In/Out	Strong drive	HiZ Analog Unb
P2[1]	63	\LCD:LCDPort[1]\	Software In/Out	Strong drive	HiZ Analog Unb
P2[2]	64	\LCD:LCDPort[2]\	Software In/Out	Strong drive	HiZ Analog Unb
P2[3]	65	\LCD:LCDPort[3]\	Software In/Out	Strong drive	HiZ Analog Unb
P2[4]	66	\LCD:LCDPort[4]\	Software In/Out	Strong drive	HiZ Analog Unb
P2[5]	68	\LCD:LCDPort[5]\	Software In/Out	Strong drive	HiZ Analog Unb

Port	Pin	Name	Type	Drive Mode	Reset State
P2[6]	1	\LCD:LCDPort[6]\	Software In/Out	Strong drive	HiZ Analog Unb
P2[7]	2	GPIO [unused]			HiZ Analog Unb
P3[0]	29	GPIO [unused]			HiZ Analog Unb
P3[1]	30	GPIO [unused]			HiZ Analog Unb
P3[2]	31	GPIO [unused]			HiZ Analog Unb
P3[3]	32	GPIO [unused]			HiZ Analog Unb
P3[4]	33	Reference_Electrode	Analog	HiZ analog	HiZ Analog Unb
P3[5]	34	pin_DAC	Analog	HiZ analog	HiZ Analog Unb
P3[6]	36	Counter_Electrode	Analog	HiZ analog	HiZ Analog Unb
P3[7]	37	GPIO [unused]			HiZ Analog Unb

Abbreviations used in Table 4 have the following meanings:

- HiZ Analog Unb = Hi-Z Analog Unbuffered
- HiZ analog = High impedance analog

2.3 Software Pins

Table 5 contains information about the software pins on this device in alphabetical order. (Only software-accessible pins are shown.)

Table 5. Software Pins

Name	Port	Type	Reset State
\LCD:LCDPort[0]\	P2[0]	Software In/Out	HiZ Analog Unb
\LCD:LCDPort[1]\	P2[1]	Software In/Out	HiZ Analog Unb
\LCD:LCDPort[2]\	P2[2]	Software In/Out	HiZ Analog Unb
\LCD:LCDPort[3]\	P2[3]	Software In/Out	HiZ Analog Unb
\LCD:LCDPort[4]\	P2[4]	Software In/Out	HiZ Analog Unb
\LCD:LCDPort[5]\	P2[5]	Software In/Out	HiZ Analog Unb
\LCD:LCDPort[6]\	P2[6]	Software In/Out	HiZ Analog Unb
\USB:Dm\	P15[7]	Analog	HiZ Analog Unb
\USB:Dp\	P15[6]	Analog	HiZ Analog Unb
Counter_Electrode	P3[6]	Analog	HiZ Analog Unb
Debug:SWD_CK	P1[1]	Reserved	
Debug:SWD_IO	P1[0]	Reserved	
Debug:SWV	P1[3]	Reserved	
GPIO [unused]	P3[2]		HiZ Analog Unb
GPIO [unused]	P3[3]		HiZ Analog Unb
GPIO [unused]	P3[0]		HiZ Analog Unb
GPIO [unused]	P3[1]		HiZ Analog Unb
GPIO [unused]	P0[1]		HiZ Analog Unb
GPIO [unused]	P3[7]		HiZ Analog Unb
GPIO [unused]	P15[3]		HiZ Analog Unb
GPIO [unused]	P15[2]		HiZ Analog Unb
GPIO [unused]	P2[7]		HiZ Analog Unb
GPIO [unused]	P0[3]		HiZ Analog Unb
GPIO [unused]	P15[5]		HiZ Analog Unb
GPIO [unused]	P1[4]		HiZ Analog Unb
GPIO [unused]	P1[5]		HiZ Analog Unb
GPIO [unused]	P1[6]		HiZ Analog Unb
GPIO [unused]	P1[7]		HiZ Analog Unb
GPIO [unused]	P0[6]		HiZ Analog Unb
GPIO [unused]	P0[5]		HiZ Analog Unb
GPIO [unused]	P0[4]		HiZ Analog Unb
GPIO [unused]	P1[2]		HiZ Analog Unb
GPIO [unused]	P15[4]		HiZ Analog Unb
LED_DAC	P0[0]	Software In/Out	HiZ Analog Unb
pin_DAC	P3[5]	Analog	HiZ Analog Unb
pin_TIA_CAP	P0[2]	Analog	HiZ Analog Unb
Reference_Electrode	P3[4]	Analog	HiZ Analog Unb
SIO [unused]	P12[6]		HiZ Analog Unb

Name	Port	Type	Reset State
SIO [unused]	P12[4]		HiZ Analog Unb
SIO [unused]	P12[5]		HiZ Analog Unb
SIO [unused]	P12[0]		HiZ Analog Unb
SIO [unused]	P12[2]		HiZ Analog Unb
SIO [unused]	P12[3]		HiZ Analog Unb
SIO [unused]	P12[1]		HiZ Analog Unb
SIO [unused]	P12[7]		HiZ Analog Unb
Working_Electrode	P0[7]	Analog	HiZ Analog Unb
XTAL:Xi	P15[0]	Reserved	
XTAL:Xi	P15[1]	Reserved	

Abbreviations used in Table 5 have the following meanings:

- HiZ Analog Unb = Hi-Z Analog Unbuffered

For more information on reading, writing and configuring pins, please refer to:

- Pins chapter in the [System Reference Guide](#)
 - CyPins API routines
- Programming Application Interface section in the [cy_pins component datasheet](#)

3 System Settings

3.1 System Configuration

Table 6. System Configuration Settings

Name	Value
Device Configuration Mode	Compressed
Enable Error Correcting Code (ECC)	False
Store Configuration Data in ECC Memory	True
Instruction Cache Enabled	True
Enable Fast IMO During Startup	True
Unused Bonded IO	Allow but warn
Heap Size (bytes)	0x80
Stack Size (bytes)	0x0800
Include CMSIS Core Peripheral Library Files	True

3.2 System Debug Settings

Table 7. System Debug Settings

Name	Value
Debug Select	SWD+SWV (serial wire debug and viewer)
Enable Device Protection	False
Embedded Trace (ETM)	False
Use Optional XRES	False

3.3 System Operating Conditions

Table 8. System Operating Conditions

Name	Value
VDDA (V)	5.0
VDDD (V)	5.0
VDDIO0 (V)	5.0
VDDIO1 (V)	5.0
VDDIO2 (V)	5.0
VDDIO3 (V)	5.0
Variable VDDA	False
Temperature Range	-40C - 85/125C

4 Clocks

The clock system includes these clock resources:

- Four internal clock sources increase system integration:
 - 3 to 74.7 MHz Internal Main Oscillator (IMO) $\pm 1\%$ at 3 MHz
 - 1 kHz, 33 kHz, and 100 kHz Internal Low Speed Oscillator (ILO) outputs
 - 12 to 80 MHz clock doubler output, sourced from IMO, MHz External Crystal Oscillator (MHzECO), and Digital System Interconnect (DSI)
 - 24 to 80 MHz fractional Phase-Locked Loop (PLL) sourced from IMO, MHzECO, and DSI
- Clock generated using a DSI signal from an external I/O pin or other logic
- Two external clock sources provide high precision clocks:
 - 4 to 25 MHz External Crystal Oscillator (MHzECO)
 - 32.768 kHz External Crystal Oscillator (kHzECO) for Real Time Clock (RTC)
- Dedicated 16-bit divider for bus clock
- Eight individually sourced 16-bit clock dividers for the digital system peripherals
- Four individually sourced 16-bit clock dividers with skew for the analog system peripherals
- IMO has a USB mode that synchronizes to USB host traffic, requiring no external crystal for USB. (USB equipped parts only)

Figure 3. System Clock Configuration

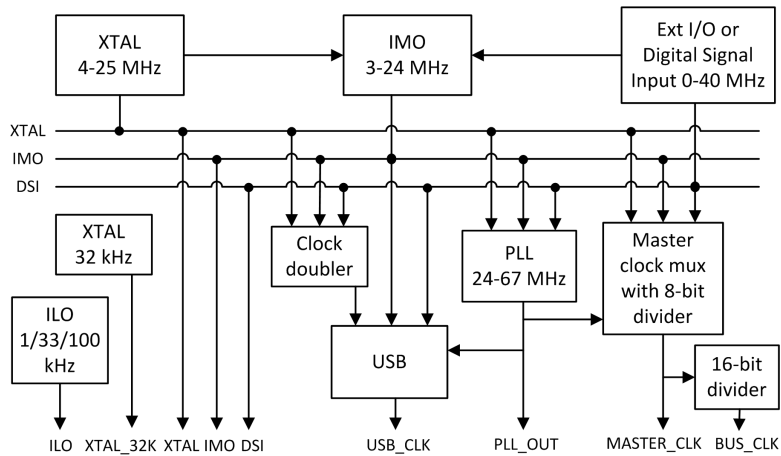

4.1 System Clocks

Table 9 lists the system clocks used in this design.

Table 9. System Clocks

Name	Domain	Source	Desired Freq	Nominal Freq	Accuracy (%)	Start at Reset	Enabled
USB_CLK	DIGITAL	IMO	48 MHz	48 MHz	±0.25	False	True
IMO	DIGITAL		24 MHz	24 MHz	±0.25	True	True
MASTER_CLK	DIGITAL	PLL_OUT	? MHz	24 MHz	±0.25	True	True
BUS_CLK	DIGITAL	MASTER_CLK	? MHz	24 MHz	±0.25	True	True
PLL_OUT	DIGITAL	IMO	24 MHz	24 MHz	±0.25	True	True
XTAL	DIGITAL		24 MHz	24 MHz	±0	False	True
ILO	DIGITAL		? MHz	100 kHz	-55,+100	True	True
XTAL 32kHz	DIGITAL		32.768 kHz	? MHz	±0	False	False
Digital Signal	DIGITAL		? MHz	? MHz	±0	False	False

4.2 Local and Design Wide Clocks

Local clocks drive individual analog and digital blocks. Design wide clocks are a user-defined optimization, where two or more analog or digital blocks that share a common clock profile (frequency, etc) can be driven from the same clock divider output source.

Figure 4. Local and Design Wide Clock Configuration

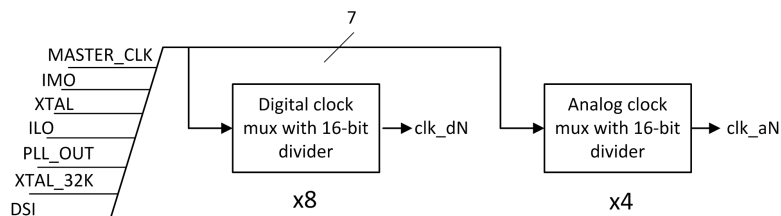

Table 10 lists the local clocks used in this design.

Table 10. Local Clocks

Name	Domain	Source	Desired Freq	Nominal Freq	Accuracy (%)	Start at Reset	Enabled
ADC_Ext_CP_- Clk	DIGITAL	MASTER_CLK	? MHz	24 MHz	±0.25	True	True
timer_clock	DIGITAL	BUS_CLK	? MHz	24 MHz	±0.25	True	True
DVDAC_BUS_- CLK	DIGITAL	BUS_CLK	? MHz	24 MHz	±0.25	True	True
ADC_theACLK	ANALOG	MASTER_CLK	960 kHz	960 kHz	±0.25	True	True
DVDAC_- IntClock	DIGITAL	MASTER_CLK	250 kHz	250 kHz	±0.25	True	True

For more information on clocking resources, please refer to:

- Clocking System chapter in the [PSoC 5LP Technical Reference Manual](#)
- Clocking chapter in the [System Reference Guide](#)
 - CyPLL API routines
 - CyIMO API routines

- CyILO API routines
- CyMaster API routines
- CyXTAL API routines

5 Interrupts and DMAs

5.1 Interrupts

This design contains the following interrupt components: (0 is the highest priority)

Table 11. Interrupts

Name	Intr Num	Vector	Priority
USB_ep_1	0	0	7
USB_ep_2	1	1	7
isr_ADC	2	2	7
isr_DAC	3	3	7
USB_dp_int	12	12	7
USB_arb_int	22	22	7
USB_bus_reset	23	23	7
USB_ep_0	24	24	7
ADC_IRQ	29	29	7

For more information on interrupts, please refer to:

- Interrupt Controller chapter in the [PSoC 5LP Technical Reference Manual](#)
- Interrupts chapter in the [System Reference Guide](#)
 - CyInt API routines and related registers
- Datasheet for [cy_isr component](#)

5.2 DMAs

This design contains the following DMA components: (0 is the highest priority)

Table 12. DMAs

Name	Priority	Channel Number
DVDAC_DMA	2	0

For more information on DMAs, please refer to:

- PHUB and DMAC chapter in the [PSoC 5LP Technical Reference Manual](#)
- DMA chapter in the [System Reference Guide](#)
 - DMA API routines and related registers
- Datasheet for [cy_dma component](#)

6 Flash Memory

PSoC 5LP devices offer a host of Flash protection options and device security features that you can leverage to meet the security and protection requirements of an application. These requirements range from protecting configuration settings or Flash data to locking the entire device from external access.

Table 13 lists the Flash protection settings for your design.

Table 13. Flash Protection Settings

Start Address	End Address	Protection Level
0x0	0x3FFFF	U - Unprotected

Flash memory is organized as rows with each row of flash having 256 bytes. Each flash row can be assigned one of four protection levels:

- U - Unprotected
- F - Factory Upgrade
- R - Field Upgrade
- W - Full Protection

For more information on Flash memory and protection, please refer to:

- Flash Protection chapter in the [PSoC 5LP Technical Reference Manual](#)
- Flash and EEPROM chapter in the [System Reference Guide](#)
 - CyWrite API routines
 - CyFlash API routines

7 Design Contents

This design's schematic content consists of the following schematic sheet:

7.1 Schematic Sheet: Potentiostat

Figure 5. Schematic Sheet: Potentiostat

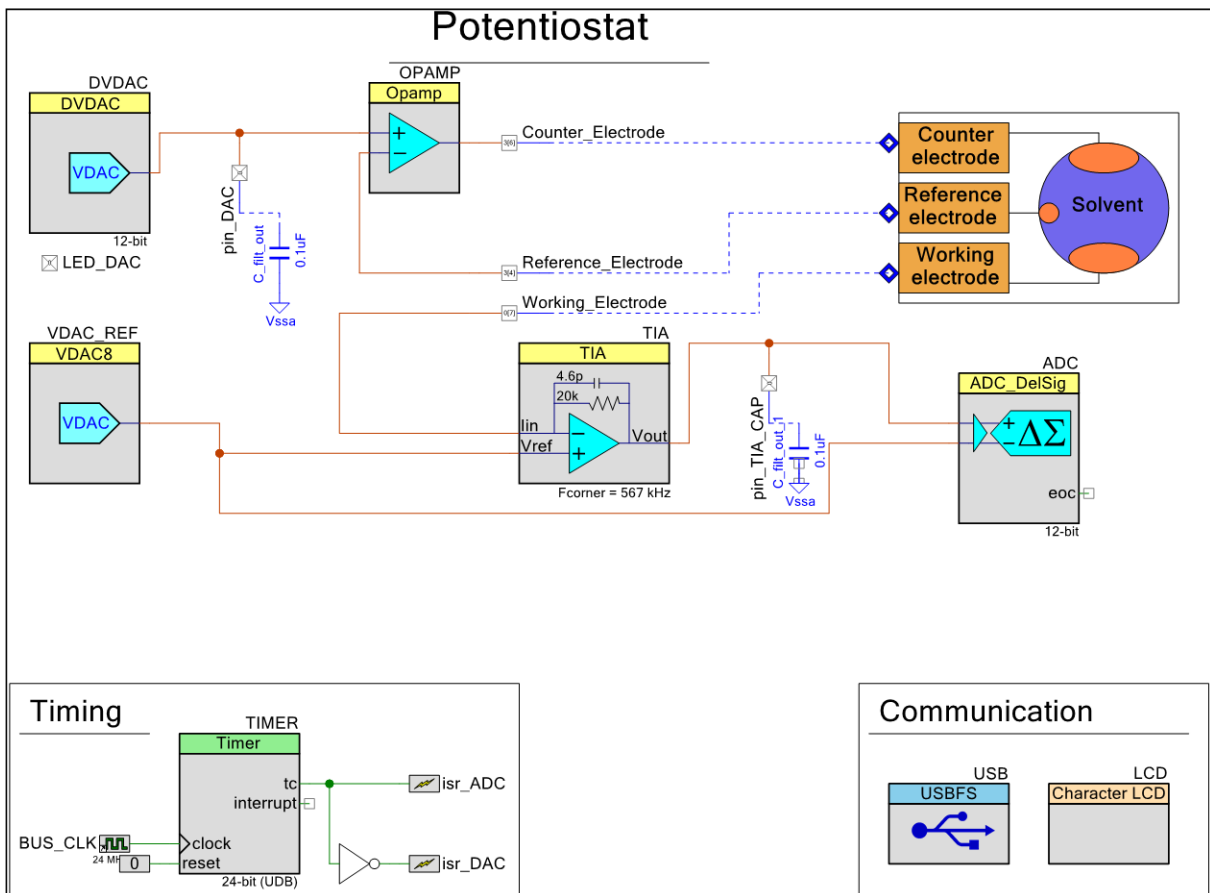

This schematic sheet contains the following component instances:

- Instance [ADC](#) (type: ADC_DelSig_v3_30)
- Instance [DVDAC](#) (type: DVDAC_v2_10)
- Instance [LCD](#) (type: CharLCD_v2_20)
- Instance [OPAMP](#) (type: OpAmp_v1_90)
- Instance [TIA](#) (type: TIA_v2_0)
- Instance [TIMER](#) (type: Timer_v2_80)
- Instance [USB](#) (type: USBFS_v3_20)
- Instance [VDAC_REF](#) (type: VDAC8_v1_90)

8 Components

8.1 Component type: ADC_DelSig [v3.30]

8.1.1 Instance ADC

Description: Delta-Sigma ADC

Instance type: ADC_DelSig [v3.30]

Datasheet: [online component datasheet for ADC_DelSig](#)

Table 14. Component Parameters for ADC

Parameter Name	Value	Description
ADC_Alignment	Right	This parameter determines how the result is aligned in the 24 bit result word.
ADC_Alignment_Config2	Right	This parameter determines how the result is aligned in the 24 bit result word.
ADC_Alignment_Config3	Right	This parameter determines how the result is aligned in the 24 bit result word.
ADC_Alignment_Config4	Right	This parameter determines how the result is aligned in the 24 bit result word.
ADC_Charge_Pump_Clock	true	Low power charge pump clock selection
ADC_Clock	Internal	Parameter for selecting the ADC clock type.
ADC_Input_Mode	Differential	Differential or Single ended input mode
ADC_Input_Range	-Input +/- 2*Vref	Choose input operating mode that best supports the range of the signals being measured.
ADC_Input_Range_Config2	-Input +/- Vref	Choose input operating mode that best supports the range of the signals being measured.
ADC_Input_Range_Config3	-Input +/- Vref	Choose input operating mode that best supports the range of the signals being measured.
ADC_Input_Range_Config4	-Input +/- Vref	Choose input operating mode that best supports the range of the signals being measured.
ADC_Power	Medium Power	Sets power level of ADC.
ADC_Reference	Internal 1.024 Volts	Selects voltage reference source and configuration.
ADC_Reference_Config2	Internal 1.024 Volts	Selects voltage reference source and configuration.
ADC_Reference_Config3	Internal 1.024 Volts	Selects voltage reference source and configuration.
ADC_Reference_Config4	Internal 1.024 Volts	Selects voltage reference source and configuration.
ADC_Resolution	12	ADC Resolution in bits
ADC_Resolution_Config2	16	ADC Resolution in bits
ADC_Resolution_Config3	16	ADC Resolution in bits
ADC_Resolution_Config4	16	ADC Resolution in bits

Parameter Name	Value	Description
Clock_Frequency	64000	Determines the ADC clock frequency.
Comment_Config1	Cyclic voltammetry	Parameter which holds the user comment for the config1.
Comment_Config2	Second Config	Parameter which holds the user comment for the config2.
Comment_Config3	Third Config	Parameter which holds the user comment for the config3.
Comment_Config4	Fourth Config	Parameter which holds the user comment for the config4.
Config1_Name	CV	This parameter is used to create constants in the header file for config 1.
Config2_Name	CFG2	This parameter is used to create constants in the header file for config 2.
Config3_Name	CFG3	This parameter is used to create constants in the header file for config 3.
Config4_Name	CFG4	This parameter is used to create constants in the header file for config 4.
Configs	1	Number of active configurations
Conversion_Mode	2 - Continuous	ADC conversion mode
Conversion_Mode_Config2	2 - Continuous	ADC conversion mode
Conversion_Mode_Config3	2 - Continuous	ADC conversion mode
Conversion_Mode_Config4	2 - Continuous	ADC conversion mode
Enable_Vref_Vss	false	Determines whether or not to connect ADC's reference Vssa to AGL[6].
EnableModulatorInput	false	When this parameter is enabled, the modulator input terminal will be enabled on the symbol.
Input_Buffer_Gain	1	Gain of input amplifier
Input_Buffer_Gain_Config2	1	Gain of input amplifier
Input_Buffer_Gain_Config3	1	Gain of input amplifier
Input_Buffer_Gain_Config4	1	Gain of input amplifier
Input_Buffer_Mode	Level Shift	Buffer Mode type selection
Input_Buffer_Mode_Config2	Rail to Rail	Buffer Mode type selection
Input_Buffer_Mode_Config3	Rail to Rail	Buffer Mode type selection
Input_Buffer_Mode_Config4	Rail to Rail	Buffer Mode type selection
Ref_Voltage	1.024	Set reference voltage
Ref_Voltage_Config2	1.024	Set reference voltage
Ref_Voltage_Config3	1.024	Set reference voltage
Ref_Voltage_Config4	1.024	Set reference voltage
rm_int	false	Removes internal interrupt (IRQ)
Sample_Rate	30000	Sample Rate in Hz
Sample_Rate_Config2	10000	Sample Rate in Hz
Sample_Rate_Config3	10000	Sample Rate in Hz
Sample_Rate_Config4	10000	Sample Rate in Hz
Start_of_Conversion	Software	Continuous conversions or hardware controlled
User Comments		Instance-specific comments.

8.2 Component type: CharLCD [v2.20]

8.2.1 Instance LCD

Description: Character LCD Component

Instance type: CharLCD [v2.20]

Datasheet: [online component datasheet for CharLCD](#)

Table 15. Component Parameters for LCD

Parameter Name	Value	Description
ConversionRoutines	true	Defines if the conversion routines will be included in the project.
CustomCharacterSet	None	Defines the type of custom character set (User defined, Vertical or Horizontal bargraph). Based on the selection a look-up table with proper characters representation will be generated in the source code.
User Comments		Instance-specific comments.

8.3 Component type: DVDAC [v2.10]

8.3.1 Instance DVDAC

Description: 9 to 12 bit Dithered Voltage DAC

Instance type: DVDAC [v2.10]

Datasheet: [online component datasheet for DVDAC](#)

Table 16. Component Parameters for DVDAC

Parameter Name	Value	Description
DAC_Range	4 Volt	This parameter allows you to set one of the two voltage ranges. This option cannot be changed during runtime.
Initial_Value	2048	This parameter allows you to set the DVDAC voltage value. The maximum value will depend on the resolution selected. Refer to the DVDAC_SetValue() function description in this component datasheet.
InternalClock	true	This parameter allows you to configure the component's clock source: internal or external. This option cannot be changed during runtime.
InternalClockFreqHz	250000	When the clock source is configured to be internal, this parameter defines the frequency in Hz at which DMA is triggered. The parameter also writes the next value from the dithered array into the VDACC8 data register.

Parameter Name	Value	Description
Resolution	12 Bits	This parameter allows you to set the DVDAC resolution. The resolution cannot be changed during runtime.
User Comments		Instance-specific comments.

8.4 Component type: OpAmp [v1.90]

8.4.1 Instance OPAMP

Description: Opamp

Instance type: OpAmp [v1.90]

Datasheet: [online component datasheet for OpAmp](#)

Table 17. Component Parameters for OPAMP

Parameter Name	Value	Description
Mode	OpAmp	Selects between uncommitted op-amp or follower mode.
Power	Low Power	Selects the device power level.
User Comments		Instance-specific comments.

8.5 Component type: TIA [v2.0]

8.5.1 Instance TIA

Description: Trans-Impedance Amplifier

Instance type: TIA [v2.0]

Datasheet: [online component datasheet for TIA](#)

Table 18. Component Parameters for TIA

Parameter Name	Value	Description
Capacitive_Feedback	4.6 pF	Capacitive feedback for the TIA
Fcorner	567 kHz	Calculated -3dB frequency for the given feedback settings.
Power	Medium Power	Power setting for TIA
Resistive_Feedback	20k ohms	Nominal resistive feedback for the TIA
User Comments		Instance-specific comments.

8.6 Component type: Timer [v2.80]

8.6.1 Instance TIMER

Description: 8, 16, 24 or 32-bit Timer

Instance type: Timer [v2.80]

Datasheet: [online component datasheet for Timer](#)

Table 19. Component Parameters for TIMER

Parameter Name	Value	Description
CaptureAlternatingFall	false	Enables data capture on either edge but not until a valid falling edge is detected first.
CaptureAlternatingRise	false	Enables data capture on either edge but not until a valid rising edge is detected first.

Parameter Name	Value	Description
CaptureCount	2	The CaptureCount parameter works as a divider on the hardware input "capture". A CaptureCount value of 2 would result in an actual capture taking place every other time the input "capture" is changed.
CaptureCounterEnabled	false	Enables the capture counter to count capture events (up to 127) before a capture is triggered.
CaptureMode	None	This parameter defines the capture input signal requirements to trigger a valid capture event
EnableMode	Software Only	This parameter specifies the methods in enabling the component. Hardware mode makes the enable input pin visible. Software mode may reduce the resource usage if not enabled.
FixedFunction	false	Configures the component to use fixed function HW block instead of the UDB implementation.
InterruptOnCapture	false	Parameter to check whether interrupt on a capture event is enabled or disabled.
InterruptOnFIFOFull	false	Parameter to check whether interrupt on a FIFO Full event is enabled disabled.
InterruptOnTC	true	Parameter to check whether interrupt on a TC is enabled or disabled.
NumberOfCaptures	1	Number of captures allowed until the counter is cleared or disabled.
Period	16777215	Defines the timer period (This is also the reload value when terminal count is reached)
Resolution	24	Defines the resolution of the hardware. This parameter affects how many bits are used in the Period counter and defines the maximum resolution of the internal component signals.
RunMode	Continuous	Defines the hardware to run continuously, run until a terminal count is reached or run until an interrupt event is triggered.
TriggerMode	None	Defines the required trigger input signal to cause a valid trigger enable of the timer
User Comments		Instance-specific comments.

8.7 Component type: USBFS [v3.20]

8.7.1 Instance USB

Description: USB 2.0 Full Speed Device Framework

Instance type: USBFS [v3.20]

Datasheet: [online component datasheet for USBFS](#)

Table 20. Component Parameters for USB

Parameter Name	Value	Description
EnableBatteryChargDetect	false	This parameter allows to detect a charging supported USB host port using the API function USBFS_DetectPortType().
EnableCDCApi	true	Enables additional high level API's that allow the CDC device to be used similar to a UART device.
EnableMidiApi	true	Enables additional high level MIDI API's.
endpointMA	MA_Static	Endpoint memory allocation
endpointMM	EP_Manual	Endpoint memory management
epDMAautoOptimization	false	This parameter enables resource optimization for DMA with Automatic Memory Management mode. Set this parameter value to true only when a single IN endpoint is present in the device. Enabling this parameter in a multi IN endpoint device configuration causes undesired effects.
extern_cls	false	This parameter allows for user or other component to implement his own handler for Class requests. USBFS_DispatchClassRqst() function should be implemented if this parameter enabled.
extern_vbus	true	This parameter enables external VBUSDET input.
extern_vnd	false	This parameter allows for user or other component to implement his own handler for Vendor specific requests. USBFS_HandleVendorRqst() function should be implemented if this parameter enabled.
extJackCount	0	Max number of External MIDI IN Jack or OUT Jack descriptors
Gen16bitEpAccessApi	false	This parameter defines whether to generate APIs for the 16-bits endpoint access.
HandleMscRequests	true	This parameter is used to enable handling MSC requests and generate MSC APIs.
isrGroupArbiter	High	This parameter defines the interrupt group of the Arbiter Interrupt.

Parameter Name	Value	Description
isrGroupBusReset	Low	This parameter defines the interrupt group of the Bus Reset Interrupt.
isrGroupEp0	Medium	This parameter defines the interrupt group of the Control Endpoint Interrupt (EP0).
isrGroupEp1	Medium	This parameter defines the interrupt group of the Data Endpoint 1 Interrupt.
isrGroupEp2	Medium	This parameter defines the interrupt group of the Data Endpoint 2 Interrupt.
isrGroupEp3	Medium	This parameter defines the interrupt group of the Data Endpoint 3 Interrupt.
isrGroupEp4	Medium	This parameter defines the interrupt group of the Data Endpoint 4 Interrupt.
isrGroupEp5	Medium	This parameter defines the interrupt group of the Data Endpoint 5 Interrupt.
isrGroupEp6	Medium	This parameter defines the interrupt group of the Data Endpoint 6 Interrupt.
isrGroupEp7	Medium	This parameter defines the interrupt group of the Data Endpoint 7 Interrupt.
isrGroupEp8	Medium	This parameter defines the interrupt group of the Data Endpoint 8 Interrupt.
isrGroupLpm	High	This parameter defines the interrupt group of the LPM Interrupt.
isrGroupSof	Low	This parameter defines the interrupt group of the Start of Frame Interrupt.
max_interfaces_num	1	Defines maximum interfaces number
Mode	false	Specifies whether the implementation will create API for interfacing to UART component(s) for a corresponding set of external MIDI connections.
mon_vbus	false	The mon_vbus parameter adds a single VBUS monitor pin to the design. This pin must be connected to VBUS and must be assigned in the pin editor.
MscDescriptors		Mass Storage Class Descriptors
MscLogicalUnitsNum	1	This parameter allows to specify the number of logical units that should be supported by the Mass Storage device.
out_sof	false	The out_sof parameter enables Start-of-Frame output.
Pid	F232	Product ID

Parameter Name	Value	Description
powerpad_vbus	false	This parameter enables VBUS power pad
ProductName		This string is displayed by the Operating System when it is installing the mass storage device as the Product Name.
ProductRevision		This string is displayed by the Operating System when it is installing the mass storage device as the Product Revision.
rm_lpm_int	true	Removes LPM ISR
User Comments		Instance-specific comments.
VendorName		This string is displayed by the Operating System when it is installing the mass storage device as the Vendor Name.
Vid	04B4	Vendor ID

8.8 Component type: VDAC8 [v1.90]

8.8.1 Instance VDAC_REF

Description: 8-Bit Voltage DAC

Instance type: VDAC8 [v1.90]

Datasheet: [online component datasheet for VDAC8](#)

Table 21. Component Parameters for VDAC_REF

Parameter Name	Value	Description
Data_Source	CPU or DMA (Data Bus)	Selects the method in which the data is written to the vDAC.
Initial_Value	127	Configures the initial vDAC output voltage. The output uses the following relation: Initial output voltage = value*(FullRange/255). This calculated output voltage value is invalid if DAC Bus is used.
Strobe_Mode	Register Write	Selects how the data is strobed into the DAC. For a register write, the data is strobed into the DAC on each CPU or DMA write. If operating in External mode, an external data strobe signal is required.
User Comments		Instance-specific comments.
VDAC_Range	0 - 4.080V (16mV/bit)	Specifies the full voltage scale range of the vDAC
VDAC_Speed	Low Speed	Specifies the vDAC settling speed. Note that the 'Slow Speed' selection consumes less power.
Voltage	2032	This parameter sets the voltage value.

9 Other Resources

The following documents contain important information on Cypress software APIs that might be relevant to this design:

- Standard Types and Defines chapter in the [System Reference Guide](#)
 - Software base types
 - Hardware register types
 - Compiler defines
 - Cypress API return codes
 - Interrupt types and macros
- Registers
 - The full PSoC 5LP register map is covered in the [PSoC 5LP Registers Technical Reference Manual](#)
 - Register Access chapter in the [System Reference Guide](#)
 - § CY_GET API routines
 - § CY_SET API routines
- System Functions chapter in the [System Reference Guide](#)
 - General API routines
 - CyDelay API routines
 - CyVd Voltage Detect API routines
- Power Management
 - Power Supply and Monitoring chapter in the [PSoC 5LP Technical Reference Manual](#)
 - Low Power Modes chapter in the [PSoC 5LP Technical Reference Manual](#)
 - Power Management chapter in the [System Reference Guide](#)
 - § CyPm API routines
- Watchdog Timer chapter in the [System Reference Guide](#)
 - CyWdt API routines
- Cache Management
 - Cache Controller chapter in the [PSoC 5LP Technical Reference Manual](#)
 - Cache chapter in the [System Reference Guide](#)
 - § CyFlushCache() API routine