

Revision History:

Rev 1.0, (07/07/17)

1) Initial Release

Rev 2.0, (09/21/17)

- 1) Changed the net 3V3 FTDI to VDD3P3
- 2) Changed D3, D5 and B15 to PMEG3020BEP
- 3) Changed R30 to a 100K 1% Thermistor
- 4) Changed R32 to 100K, 1%
- 5) Changed USB connectors J6 and J9 to T/H Mounting parts
- 6) Add TH1, 500mA Fuse

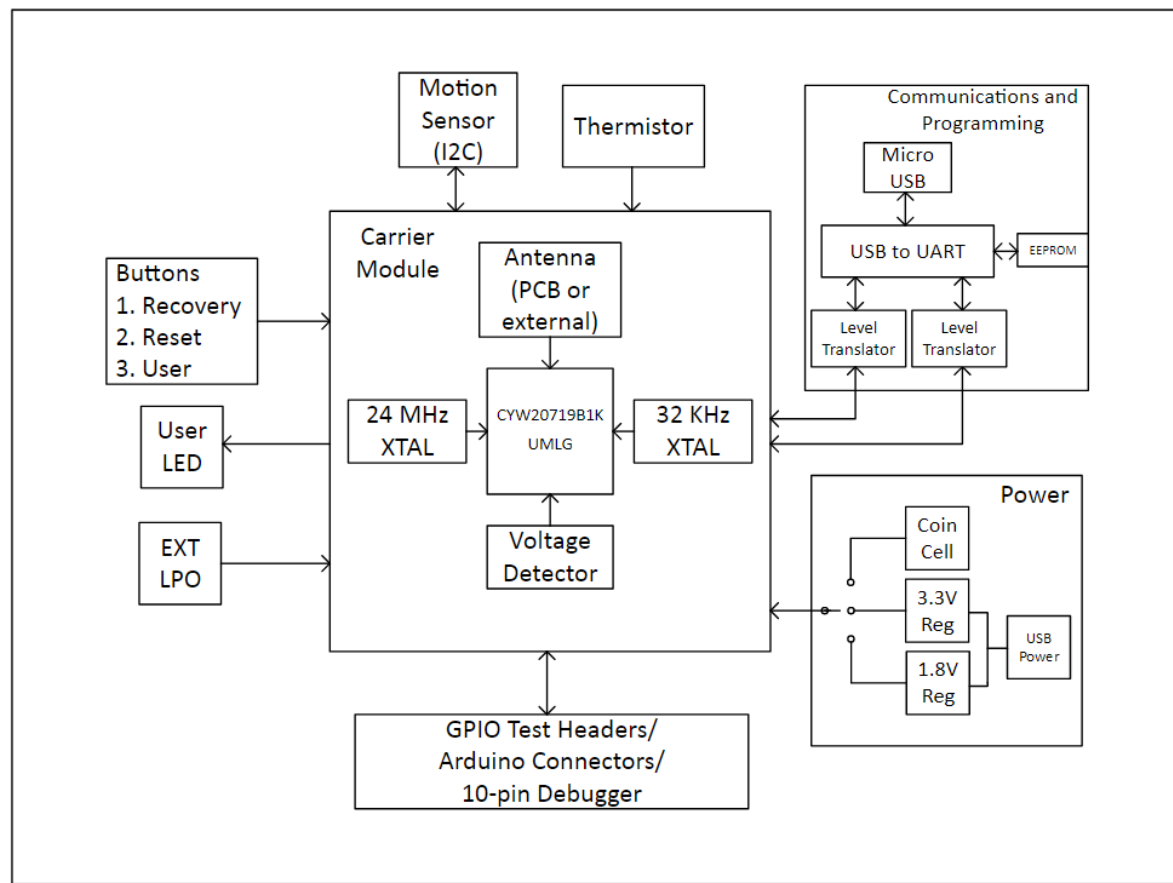

PAGE1: COVER PAGE
 PAGE2: CARRIER MODULE
 PAGE3: PERIPHERALS & SENSORS
 PAGE4: POWER
 PAGE5: USB TO UART INTERFACE

Title		
CYW9BTWCDEVAL1 - Cover Page		
Size	Document Number	Rev
	630-90523-01	2.0
Date:	Thursday, October 19, 2017	Sheet 1 of 5

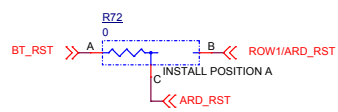
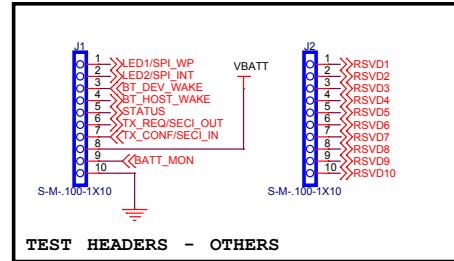
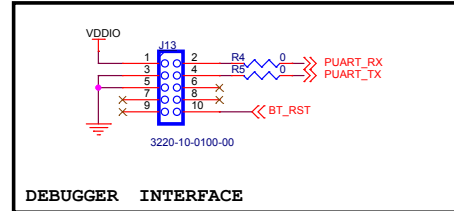
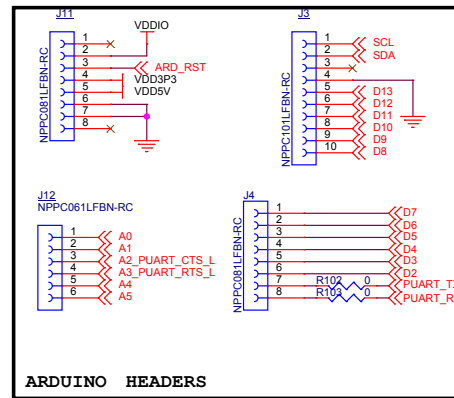
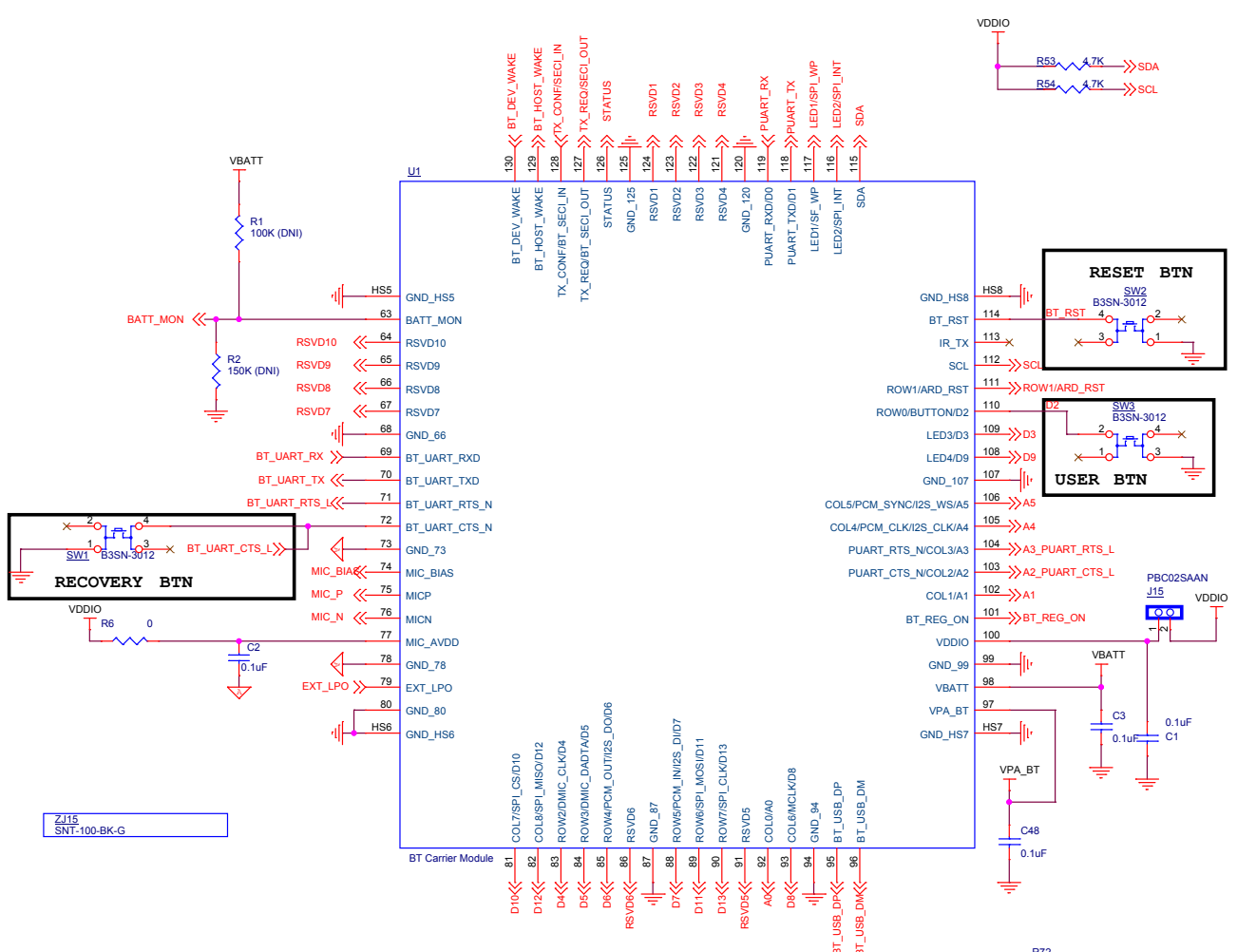

Title			
CYW9BTWCDEVAL1 - Carrier Module			
Size	Document Number	630-90523-01	Rev
			2.0
Date:	Thursday, October 19, 2017	Sheet	2 of 5

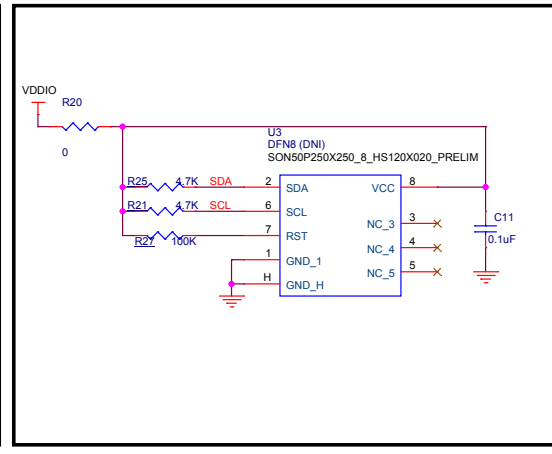
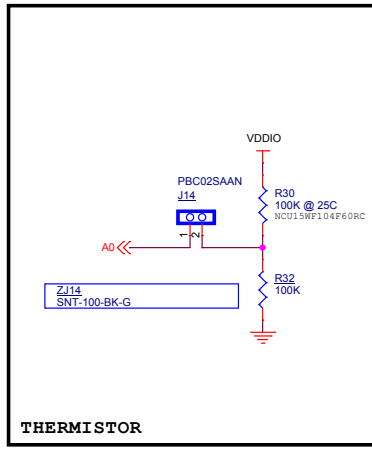
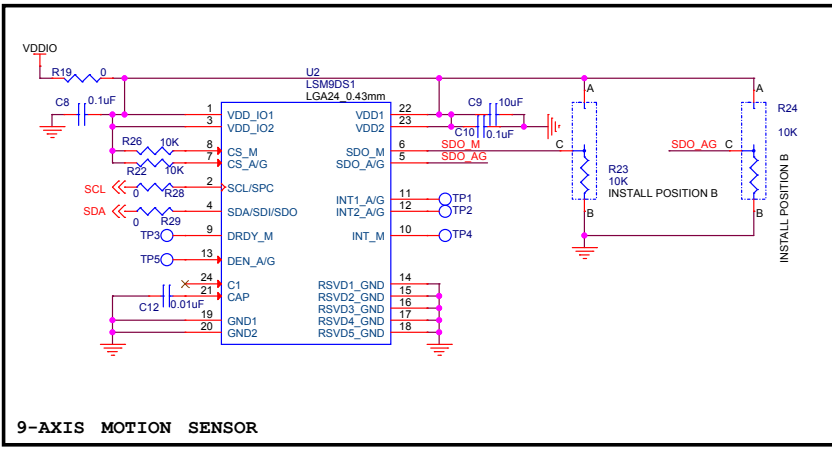
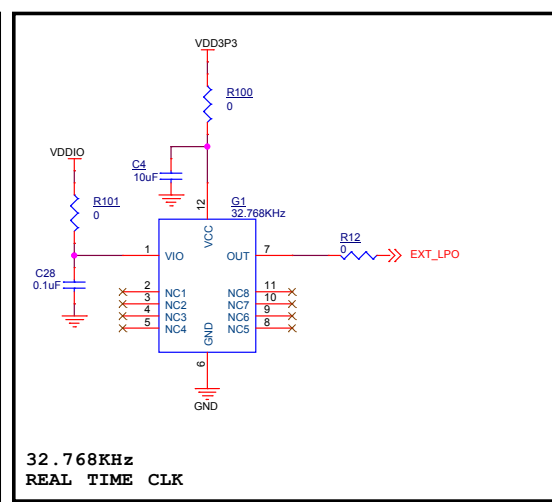
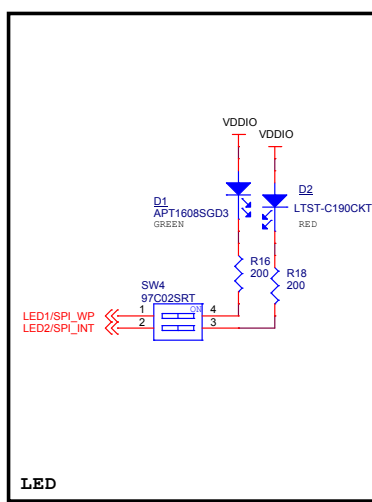
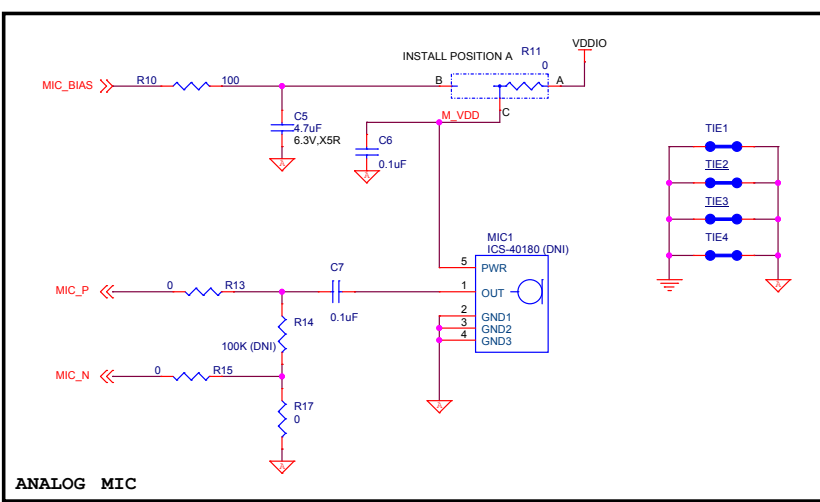

Cypress Proprietary & Confidential

Title		
CYW9BTCDEVAL1 - Peripherals and Sensors		
Size	Document Number	Rev
	630-90523-01	2.0
Date:	Thursday, October 19, 2017	Sheet 3 of 5

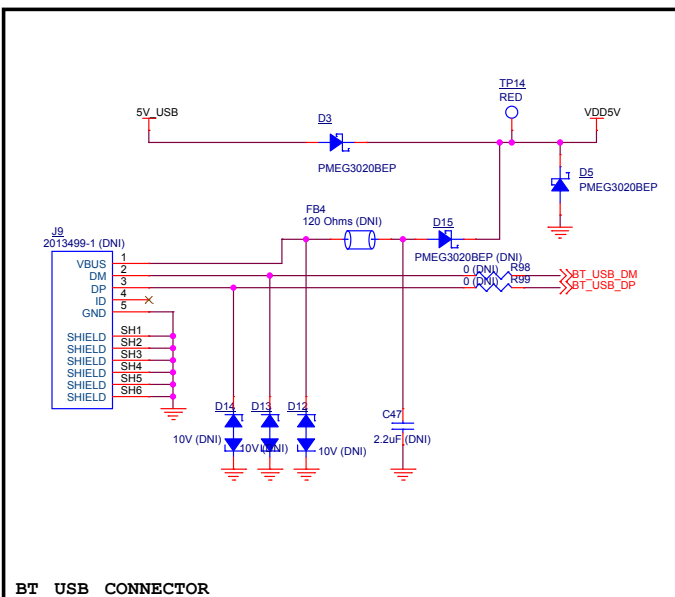

BT USB CONNECTOR

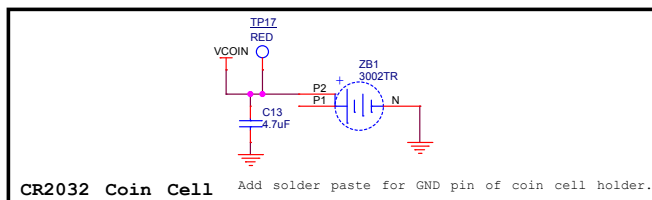

CR2032 Coin Cell Add solder paste for GND pin of coin cell holder.

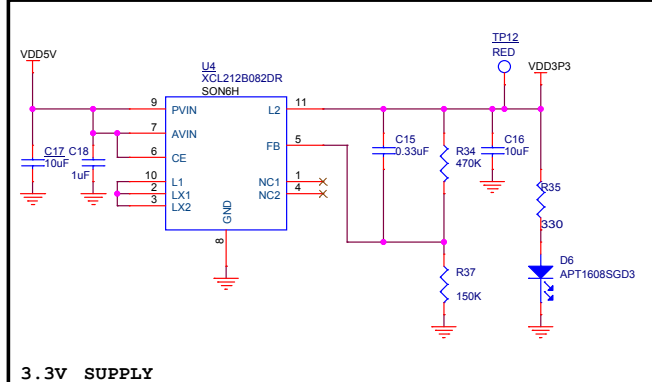
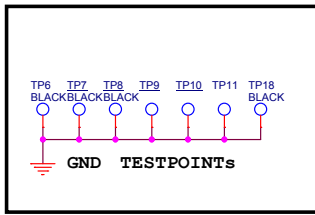
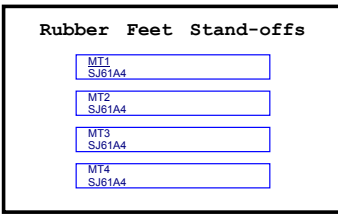
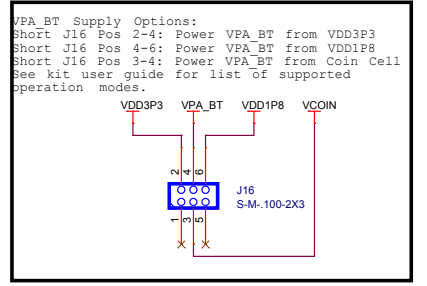
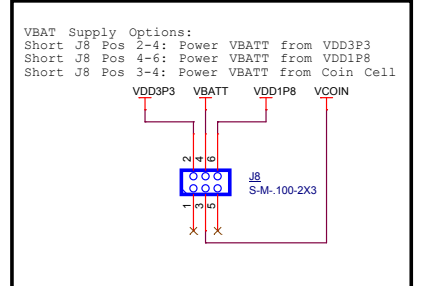
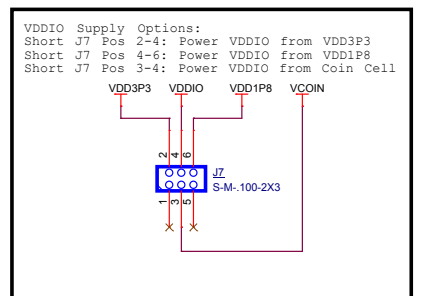

3.3V SUPPLY

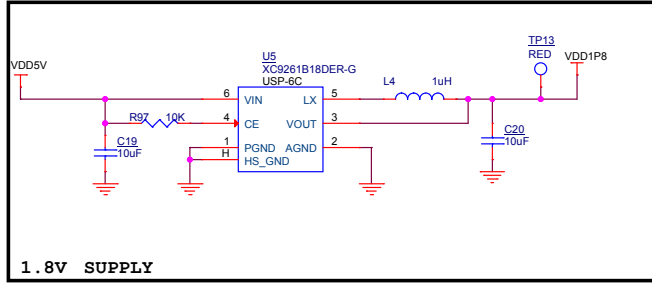

1.8V SUPPLY

Cypress Proprietary & Confidential

ZJ7-24
SNT-100-BK-G
ZJ8-24
SNT-100-BK-G

Title		
CYW9BTCDEVAL1 - Power		
Size	Document Number	Rev
	630-90523-01	2.0
Date:	Thursday, October 19, 2017	Sheet 4 of 5

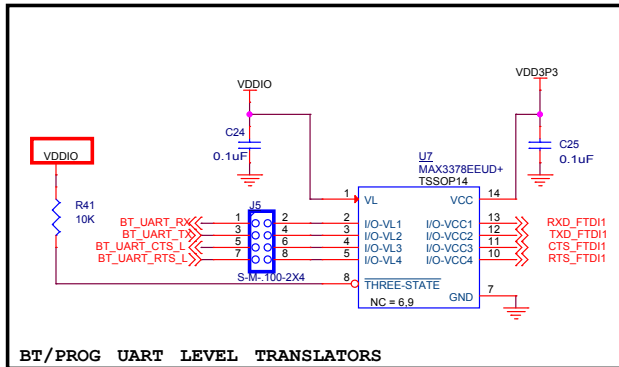

BT/PROG UART LEVEL TRANSLATORS

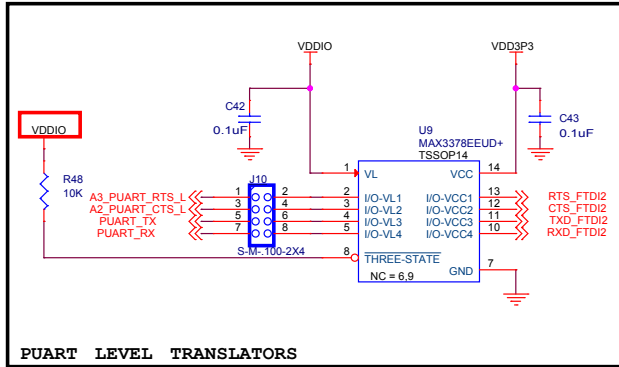

PUART LEVEL TRANSLATORS

ZJ5-1-2 SNT-100-BK-G	ZJ10-1-2 SNT-100-BK-G
ZJ5-3-4 SNT-100-BK-G	ZJ10-3-4 SNT-100-BK-G
ZJ5-5-8 SNT-100-BK-G	ZJ10-5-8 SNT-100-BK-G
ZJ5-7-8 SNT-100-BK-G	ZJ10-7-8 SNT-100-BK-G

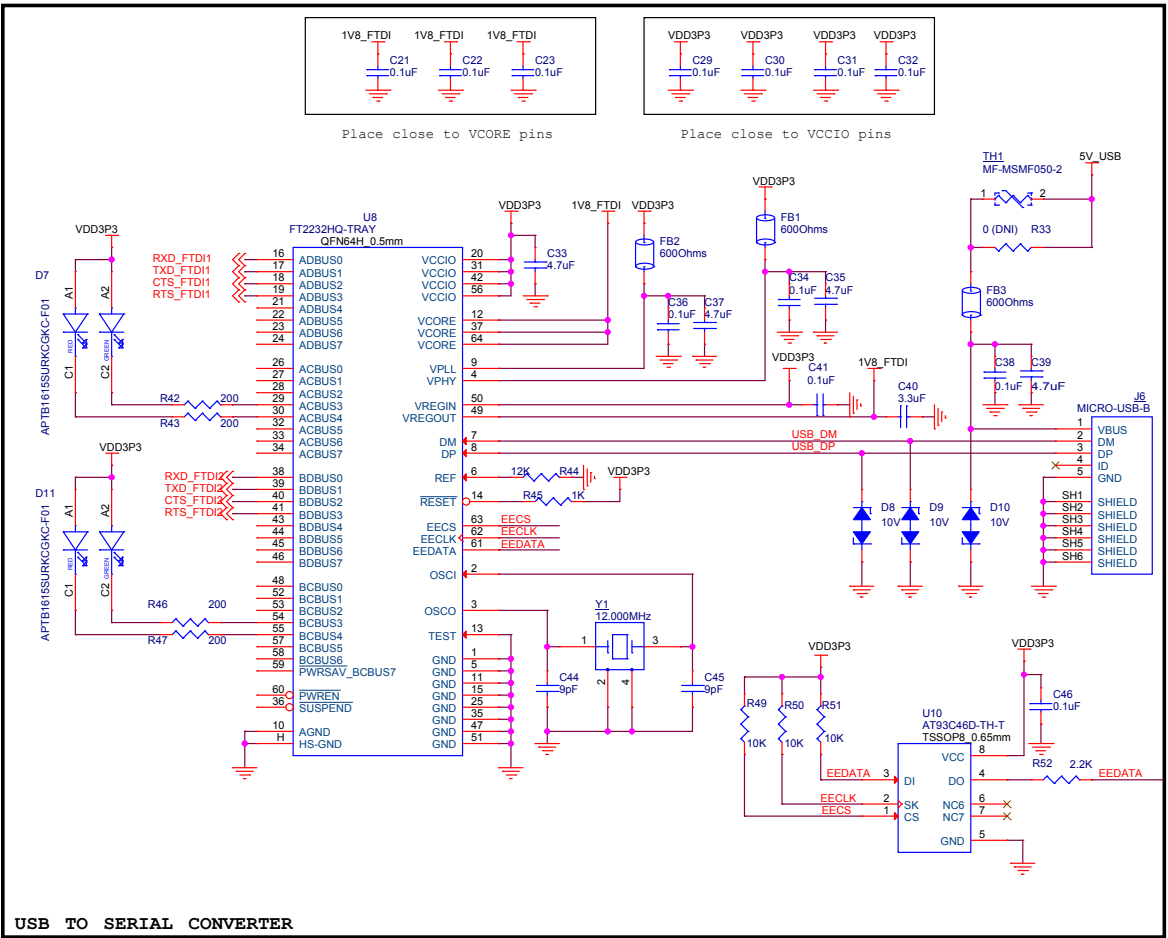

USB TO SERIAL CONVERTER

CBL1
750-90043-01
USB CABLE

Title CYW9BTWCDEVAL1 - USB TO UART		
Size B	Document Number 630-90523-01	Rev 2.0
Date: Thursday, October 19, 2017	Sheet 5 of 5	

Cypress Proprietary & Confidential

Revision History:

Rev 1.0 (07/25/17)

1) Initial Release, based on CYW920719WCD1 with 20719B2 chip

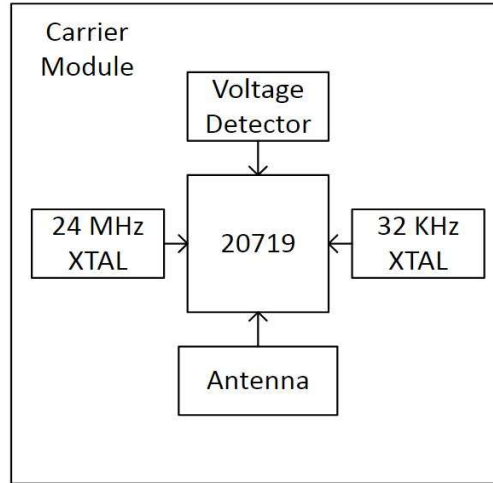

PAGE1: COVER PAGE
PAGE2: BASEBAND
PAGE3: RADIO
PAGE4: MODULE IO

Title		
CYW920719WCD2 Cover Page		
Size	Document Number	Rev
	630-90668-01	1.0
Date:	Tuesday, April 16, 2019	Sheet 1 of 4

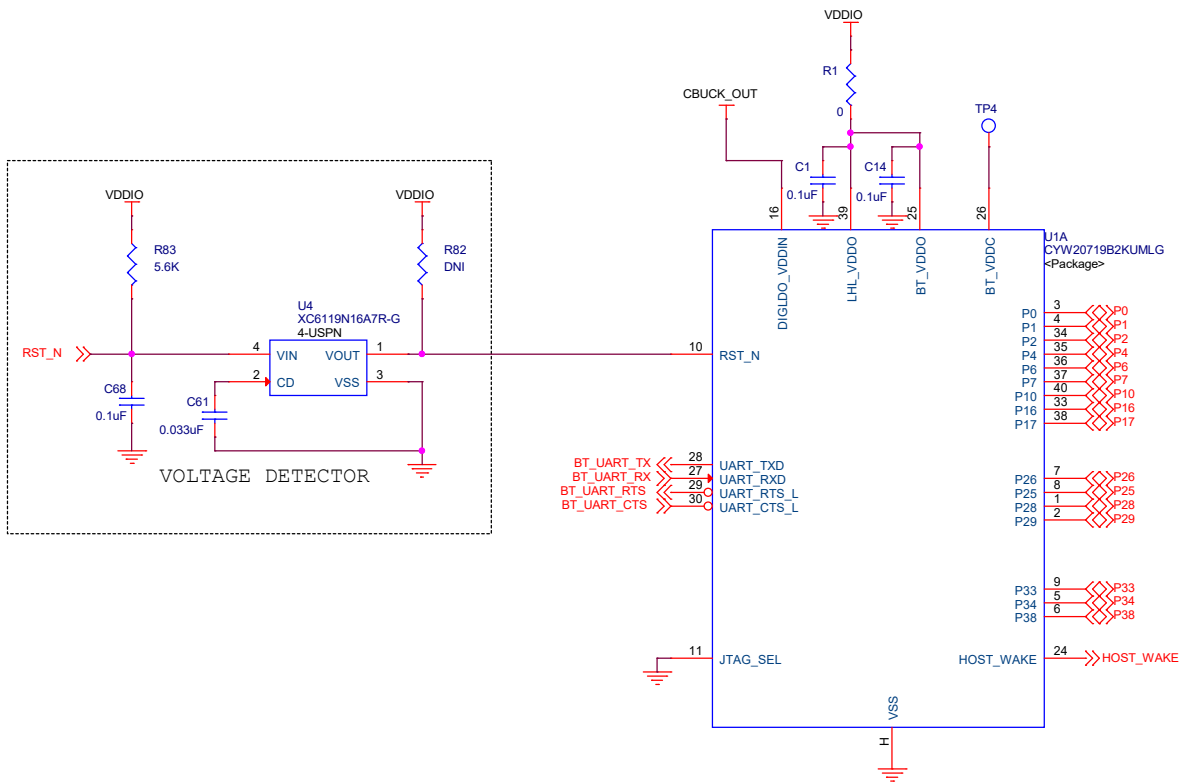

Title		
CYW920719WCD2 Baseband		
Size	Document Number	Rev
	630-90668-01	1.0
Date:	Tuesday, April 16, 2019	Sheet 2 of 4

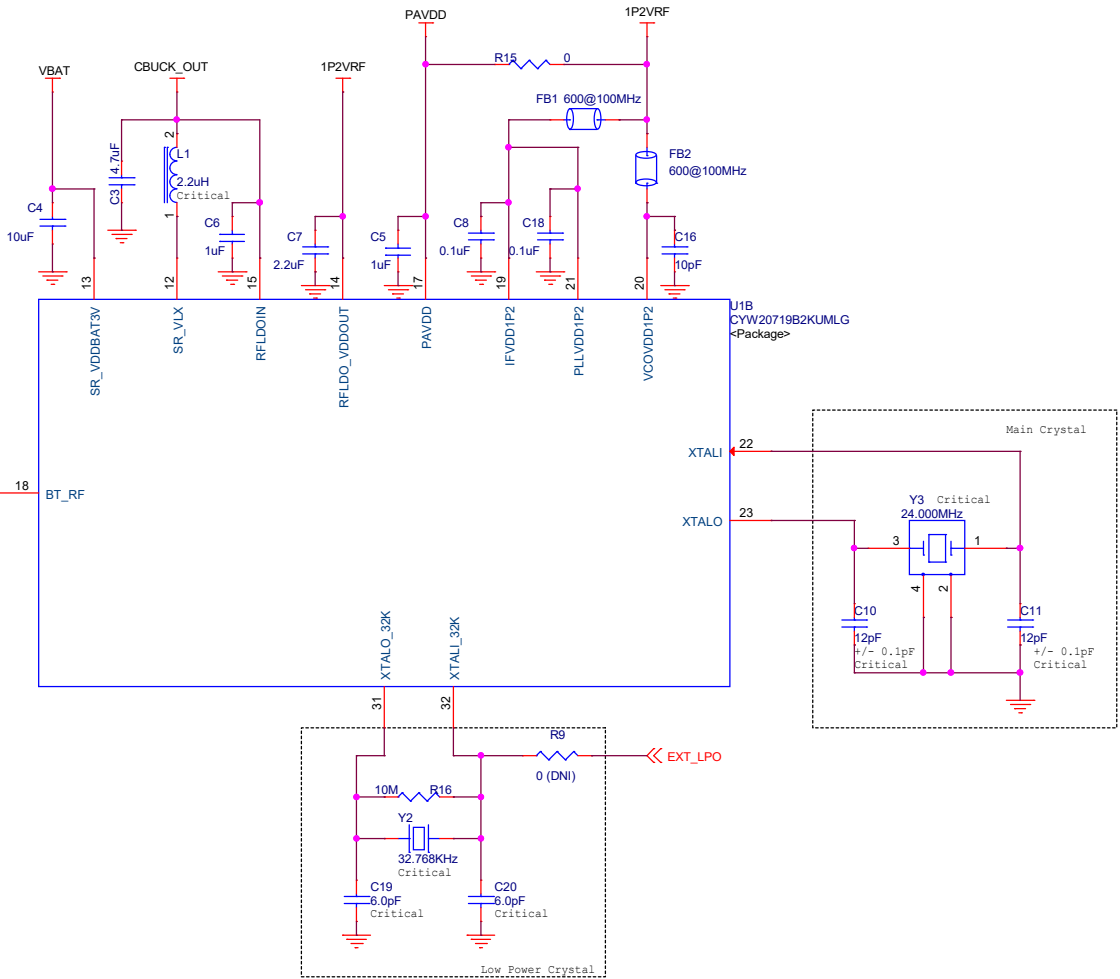
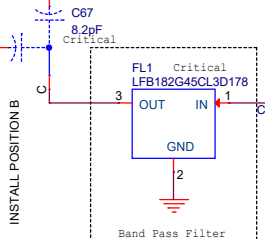
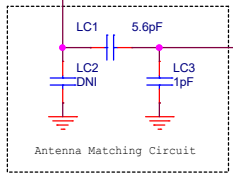
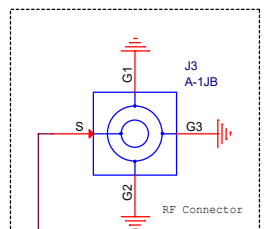
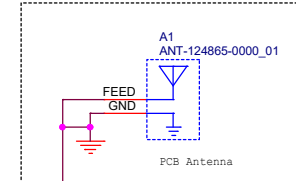

Cypress Proprietary & Confidential

Title		
CYW920719WCD2 Radio		
Size	Document Number	Rev
	630-90668-01	1.0
Date:	Tuesday, April 16, 2019	Sheet 3 of 4

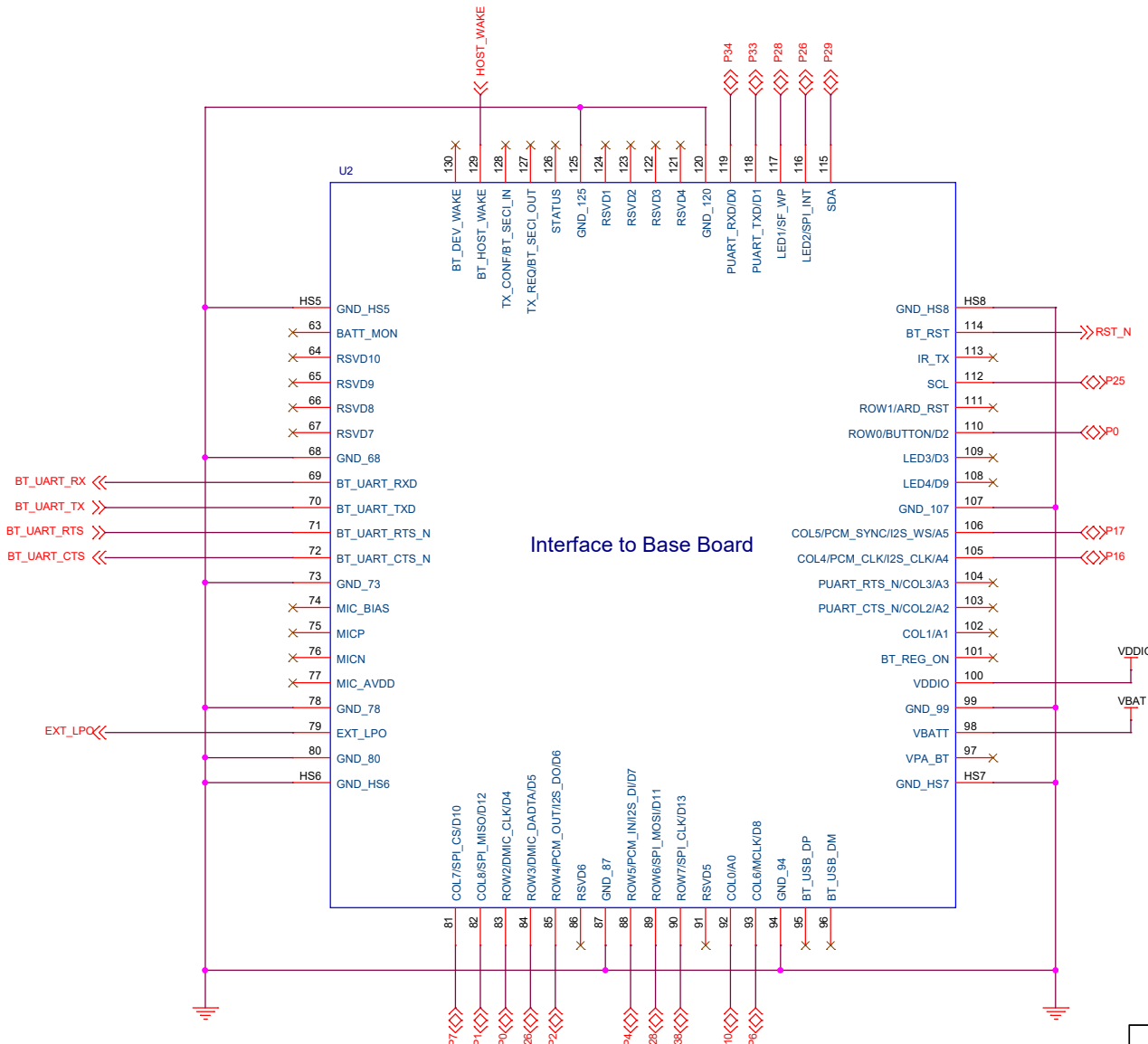

Interface to Base Board

Title		
CYW920719WCD1 Module I/O		
Size	Document Number	Rev
	630-90668-01	1.0
Date:	Tuesday, April 16, 2019	Sheet 4 of 4